



# MODEL 9100

## AUTOMATED TELLER MACHINE

### USER MANUAL

VERSION 1.0

TDN 07100-00080 04/2007

**CORPORATE HEADQUARTERS:**

522 E. Railroad Street  
Long Beach, MS 39560  
Phone: (228) 868-1317  
Fax: (228) 868-0437

**RMA (RETURN MATERIAL AUTHORIZATION)**

**RETURN ADDRESS:**  
21405 Avenue "B"  
Long Beach, MS 39560

**COPYRIGHT NOTICE**

© 2002 - 2007 Delaware Capital Formation, Inc. All Rights Reserved. Triton Systems of Delaware, Inc. is an operating company of Dover Electronics, Inc., a subsidiary of Dover Corporation (NYSE-DOV). DOVER, the DOVER logo and the family of marks and TRITON, the TRITON logo and the Triton family of marks are registered trademarks of Delaware Capital Formation, Inc., a wholly owned subsidiary of Dover Corporation.

**Guide Courtesy of**

**ATMDEPOT.COM**  
MORE MONEY IN YOUR POCKET

# MODEL 9100 USER MANUAL

---

## NOTICES

Copyright © Delaware Capital Formation, Inc., 2002 - 2007.

### ALL RIGHTS RESERVED

This publication is protected by copyright and all rights are reserved. No part of it may be reproduced or transmitted by any means or in any form, without prior consent in writing from Triton Systems of Delaware, Inc.

The information in this publication has been carefully checked and is believed to be accurate. However, Triton Systems of Delaware, Inc. assumes no responsibility for any inaccuracies, errors, or omissions that may be contained in this document. In no event will Triton Systems of Delaware, Inc. be liable for direct, indirect, special, incidental, or consequential damages resulting from any defect or omission in this manual, even if advised of the possibility of such damages.

In the interest of continued product development, Triton Systems of Delaware, Inc. reserves the right to make improvements in its documentation and the products it describes at any time, without notice or obligation.

### TRADEMARK ACKNOWLEDGEMENTS

Triton Connect is a trademark of Triton Systems of Delaware, Inc. VISA® is a registered trademark of VISA of the United States and other countries.

CONTENTS

**SECTION 1 - INTRODUCTION ..... 1**  
WHAT'S IN THIS MANUAL ..... 2  
FEATURE HIGHLIGHTS ..... 3  
STANDARD FEATURES ..... 4

**SECTION 2 - BASIC OPERATION ..... 7**  
INTRODUCTION ..... 8  
CONTROL PANEL LAYOUT ..... 8  
FUNCTION KEYPADS ..... 9  
MAIN KEYPAD ..... 9  
MENU-BASED OPERATION ..... 11  
CUSTOMER TRANSACTIONS ..... 12  
VOICE-ENABLED TRANSACTIONS ..... 14

**SECTION 3 - MANAGEMENT FUNCTIONS ..... 15**  
INTRODUCTION ..... 16  
ACCESSING THE MANAGEMENT FUNCTIONS MENU ..... 16  
NEW OR MODIFIED MANAGEMENT FUNCTIONS ..... 17

**MAIN MENU ..... 18**

**CONFIGURE TERMINAL ..... 19**  
CASSETTE SETUP ..... 19  
DATE / TIME FUNCTIONS ..... 19  
LANGUAGE IDIOMA ..... 19  
PRINTER SETTINGS ..... 19  
ATM MONITORING ..... 19  
PASSWORD MAINTENANCE ..... 19  
**MORE ..... 20**  
AD SCREENS ..... 20  
RANDOM / LEVEL PROZE COUPONS ..... 20  
CHANGE MESSAGES ..... 20  
COMMUNICATION ..... 20  
ADJUST CONTRAST ..... 20  
LOCAL ZIP CODE ..... 20  
**MORE ..... 20**  
SPEECH ON / OFF ..... 20  
VIEW / MODIFY OPTIONS ..... 20

CONTENTS

**CASSETTE SETUP ..... 21**  
RELEARN BILL THICKNESS ..... 21  
INTERNATIONAL CURRENCY ..... 21  
MAXIMUM AMOUNT (CASH) ..... 21  
MAXIMUM AMOUNT (NON-CASH) ..... 21  
CASSETTE PARAMETERS ..... 21  
FAST CASH AMOUNTS ..... 21  
**MORE ..... 21**  
LOW CURRENCY ..... 21  
EXTENDED AMOUNT ..... 21  
**CASSETTE PARAMETERS ..... 22**  
SET BILL DIMENSIONS ..... 22  
VALUE ..... 22  
TYPE ..... 22  
SERVICE ..... 22  
CURRENCY DATA ..... 22  
CASSETTE ..... 22  
DESCRIPTION ..... 22

**CONFIGURE PROCESSORS ..... 23**  
PROCESSOR NAME ..... 23  
TERMINAL ID ..... 23  
KEY MANAGEMENT ..... 23  
COMMUNICATION TYPE ..... 23  
COMMUNICATION NUMBERS ..... 23  
SENT TERMINAL TOTALS ..... 24  
STATUS MONITORING ..... 24  
EOT (END OF TRANSMISSION) ..... 24  
COMMUNICATION HEADER ..... 25  
PREDIAL ..... 25  
**KEY MANAGEMENT ..... 26**  
ENTER MASTER KEYS ..... 26  
DOWNLOAD WORKING KEYS ..... 26  
DISPLAY CHECK DIGITS ..... 26  
ENTERING KEYS PROCEDURES ..... 27-28

**CONFIGURE SERVICES ..... 29**

**STD ATM CONFIGURATION ..... 30**  
TRANSACTION TYPES ..... 30  
ACCOUNT TYPES ..... 30  
SURCHARGE ..... 30

CONTENTS

**CASSETTE SERVICE ..... 31**

**DIAGNOSTICS ..... 32**

STATUS ..... 32

PURGE ..... 32

TEST DISPENSE ..... 32

FORMAT GRAPHIC MEMORY ..... 32

TEST RECEIPT PRINTER ..... 32

VERSION #'S ..... 32

**MORE DIAGNOSTICS ..... 33**

INJECT NEW CASSETTE ID ..... 33

COMMUNICATION ..... 33

MODEM SPEAKER ON / OFF ..... 33

FORCE UNLOCK ..... 33

PRINT DISPENSER STATUS ..... 33

CLEAR DISPENSER STATUS ..... 33

PREVIOUS ..... 33

**MORE (MORE) DIAGNOSTICS ..... 34**

KEYPAD ..... 34

CLEAR TAMPER ..... 34

CLEAR SERIAL TAMPER ..... 34

STATUS ..... 34

SCAN CARD ..... 34

**CLOSE ..... 35**

SCHEDULE CLOSE ..... 35

TRIAL CLOSE ..... 35

DAY CLOSE ..... 35

TRIAL CASSETTE CLOSE (ALL) ..... 35

**CASSETTE CLOSE ..... 36**

CASSETTE A-D ..... 36

TRIAL CASSETTE CLOSE ..... 36

SELECT CASSETTE ..... 36

ENTER QTY IN CASSETTE ..... 36

**JOURNAL ..... 37**

PRINT JOURNAL ..... 37

CLEAR JOURNAL ..... 37

PRINT LAST X ENTRIES ..... 37

CONTENTS

**TCP/IP CONFIGURATION ..... 39**  
INTRODUCTION ..... 40  
TCP/IP ADDRESSES ..... 40  
**CONFIGURE PROCESSORS (COMM TYPE) ..... 41**  
COMMUNICATION NUMBERS ..... 42  
**CONFIGURE TERMINAL (TCP/IP CONFIGURATION) ..... 43**  
NETWORK SETTINGS ..... 44-45  
TEST TCP/IP ..... 46  
**TRITON CONNECT (TCP/IP CONFIGURATION) ..... 47**  
HOST NUMBERS (ADDRESSES) ..... 48  
ALARM NUMBERS (ADDRESSES) ..... 49  
TERMINAL IP ADDRESS / LISTENING PORT ..... 50

**SECTION 4 - CASSETTE CLOSE / CASH REPLENISHMENT ..... 51**  
INTRODUCTION ..... 52  
DISPENSING MECHANISMS ..... 52  
NOTE CONDITION ..... 52  
PREPARING NOTES ..... 53  
**CASSETTE CLOSE PROCEDURES ..... 54**  
**REPLENISH CASSETTE (TDM DISPENSERS) ..... 55-58**  
**REPLENISH CASSETTE (SDD) ..... 59-61**  
**REPLENISH CASSETTE (MINIMECH) ..... 62-63**

**SECTION 5 - GENERAL MAINTENANCE ..... 65**  
INTRODUCTION ..... 66  
REPLENISH RECEIPT PAPER ..... 66-68  
CLEANING THE ENCLOSURE ..... 69  
CLEANING THE DISPLAY ..... 69  
CARD READER CLEANING ..... 69

**SECTION 6 - ERROR CODES / TDM CLICK COUNTS ..... 71**  
ERROR CODES ..... 72-76  
COMMUNICATION ERROR CODES ..... 77  
CLICK COUNTER HARDWARE STATUS CODES ..... 78  
TDM CLICK COUNTERS ..... 79-85

CONTENTS

APPENDIX A - WARRANTY AND REPAIR POLICIES/PROCEDURES ..... A-1

APPENDIX B - COMBINATION / ELECTRONIC LOCKS ..... B-1

APPENDIX C - TDM “BACKGROUND PAPER” ..... C-1

SUPPLEMENTS

SUPPLEMENT A (US / MEXICO) ..... SA-1

SUPPLEMENT B (CANADA) ..... SB-1

SUPPLEMENT C (SOUTH AFRICA) ..... SC-1

SUPPLEMENT D (US) ..... SD-1

SUPPLEMENT E (CANADA) ..... SE-1

SUPPLEMENT F (UK) ..... SF-1

**THIS PAGE INTENTIONALLY LEFT BLANK**





# SECTION 1

## INTRODUCTION



## WHAT'S IN THIS MANUAL

This revised User manual describes the operating features of the Model 9100 series ATM and shows how to perform the procedures that would typically be performed by the owner or operator personnel.

The manual is divided into the following sections:

**SECTION 1, INTRODUCTION.** Summarizes the basic features of the Model 9100 series ATM.

**SECTION 2, BASIC OPERATION.** Describes the basic operation of the terminal.:

- Control Panel Layout.
- Keypads (Function, Main)
- Menu-Based Operation
- Customer Transaction Process
- Voice-Enabled Transactions Guide

**SECTION 3, MANAGEMENT FUNCTIONS.** Describes the menu functions and available options.

**SECTION 4, CASSETTE CLOSE / CASH REPLENISHMENT.** Describes the menu functions for cassette close procedures. Cash replenishment standards and loading steps are covered as well as putting cassettes back in service.

**SECTION 5, GENERAL MAINTENANCE.** Describes normal preventative and corrective maintenance procedures appropriate for user personnel.

- Replenishing Receipt Paper
- Cleaning the Enclosure/Card Reader

**Section 6, TDM Error Codes / Click Counts.** Tables provided to help identify error conditions and troubleshooting.

**APPENDIX A, WARRANTY AND REPAIR POLICIES / PROCEDURES**

**APPENDIX B, COMBINATION / ELECTRONIC LOCKS.** Covers how to change combinations for mechanical and electronic locks. Also provides procedures for changing the battery in the electronic lock.

**APPENDIX C, TALKING PAPER (TDM MECHANISMS)**

**SUPPLEMENT A.** Describes software changes implemented in the March, 06' version of 8100/9100 US/ Mexico software release.

**SUPPLEMENT B.** Describes software changes implemented in the April, 06' version of 8100/9100 Canadian software release.

## INTRODUCTION

---

**SUPPLEMENT C.** Describes software changes implemented in the May, 06' version of 8100/9100 South Africa software release.

**SUPPLEMENT D.** Describes software changes implemented in the February, 07' version of 8100/9100 US software release.

**SUPPLEMENT E.** Describes software changes implemented in the Mar, 07' version of 8100/9100 Canadian software release.

**SUPPLEMENT F.** Describes software changes implemented in the Mar, 07' version of 8100/9100 UK software release.

## FEATURE HIGHLIGHTS

Important features of the 9100 series ATM are highlighted in the following list:

- Modular architecture eases troubleshooting and servicing.
- Supports dial-up and Ethernet (TCP/IP) communications.
- Accomodates single or multi-cassette dispensing mechanisms (TDM-100/150/200/250/SDD/Minimech).
- 5.7" (145 mm) monochrome or color LCD display.
- 14.4 baud modem standard (*33.6 baud optional*).
- Satisfies Americans with Disabilities Act (ADA) specifications for height and access. Audio compliant.
- VISA® Encrypting PIN Pad (VEPP) to comply with international encryption standards and Triple DES compliant.
- Dip-style card reader (*EMV optional*).
- 60 mm thermal printer designed for quiet operation.
- Mechanical or electronic combination lock .
- Supports remote setup, configuration, and monitoring via Triton Connect™ ATM monitoring software.
- Dispenses U.S. and international currency types.
- High-capacity electronic journal stores transaction details for later printout and analysis.
- Supports LED-backlit signage option (topper attachment).
- Small footprint design makes placement easier. Deeper cabinet available to accomodate SDD dispenser.
- Choice of control panel and fascia color available in Blue or Bayou Bronze.

## STANDARD FEATURES

- ❑ **Management Functions.** Enable extensive control and customization of the ATM's operating parameters.
- ❑ **EPROM Functions.** The EPROM function provides low-level diagnostic and software update operations.
- ❑ **Password Protection.** Access to Management Functions, EPROM, and Key Management areas are protected with passwords.
- ❑ **MAC Encryption Support.** Message Authentication Code (MAC) data encryption protocol. Provides increased protection for message traffic to and from the ATM. *Triple DES compliant.*
- ❑ **Encrypting PIN Pad (EPP) Entry Device Support.** Secure EPP device encrypts the customer PIN during a transaction. *Triple DES compliant.*
- ❑ **Multi-Language Support.** Enables the customer to select a preferred language (such as French or Spanish) for customer screens and receipts.
- ❑ **Transaction and Account Type Configuration.** Enables selection of transactions (transfers or balance inquiries) or accounts (savings or credit card) that will be presented to the customer. Does not affect availability of checking account withdrawal.
- ❑ **Cassette and Day Close Reports.** Provide summary information about the number and type of transactions being performed by the ATM.
- ❑ **Electronic Journal.** Stores the details of each transaction in solid-state memory. Journal data can be retrieved, printed out at the receipt printer, and transferred to a remote Triton Connect computer.
- ❑ **AD Screens.** An Ad screen is a promotional or advertising graphic that is displayed on the LCD screen during idle periods. Ad screens are downloaded to the terminal by a remote Triton Connect™ computer. Text-only (non-graphic) Ad screens can also be displayed.
- ❑ **Receipt Printer Graphics.** This feature allows informational or promotional graphics to be printed on customer receipts.
- ❑ **Messages.** Informational and promotional messages that are displayed to the customer on-screen or printed on receipts.
- ❑ **Coupons.** Coupons are printed by the receipt printer and prizes awarded to customers based on random and/or withdrawal amount-based transactions. Coupon text can be entered locally or downloaded along with coupon graphics using Triton Connect™ software.

## INTRODUCTION

---

- ❑ **Status Monitoring.** The ATM can periodically transfer status information to the host processor. In addition, Triton Connect™ remote monitoring software can be used to view the journal, monitor operation and alarm conditions, update operating parameters, and reset the terminal.
- ❑ **UL 291 certified for Business Hours service.** This means that the currency should be removed from the dispenser and stored in a safe location when the business is closed to the public.
- ❑ **Front-access cabinet.** Allows access to the dispensing mechanism and currency cassette from the control-panel side of the unit.

**THIS PAGE INTENTIONALLY LEFT BLANK**

**SECTION 2**  
**BASIC OPERATION**

## INTRODUCTION

This section describes the basic operation of the terminal. The following topics are covered:

1. **CONTROL PANEL LAYOUT.** Describes the layout of the terminal's control panel.
2. **KEYPAD OPERATION.** Describes the use of the alphanumeric keypads.
3. **MENU-BASED OPERATION.** Gives a general overview of the terminal display interface.
4. **CUSTOMER TRANSACTIONS.** Summarizes the actions involved in typical customer transactions. In addition, the voice-enabled transactions feature is described.

## CONTROL PANEL LAYOUT

The user interface of the terminal consists of the LCD screen, receipt chute, card reader, speaker, headphone jack (visually impaired), and 24 keys on three keypads. The Function keys are arranged in two four-key groups, one group on either side of the LCD display. The main keypad consists of 10 alphanumeric keys, two arrow keys and four large control keys, all located in a 16-key group beneath the LCD screen.

The main keypad and control keys have an integral raised Braille symbol to conform to the requirements of the Americans with Disabilities Act (Figure 2-1).

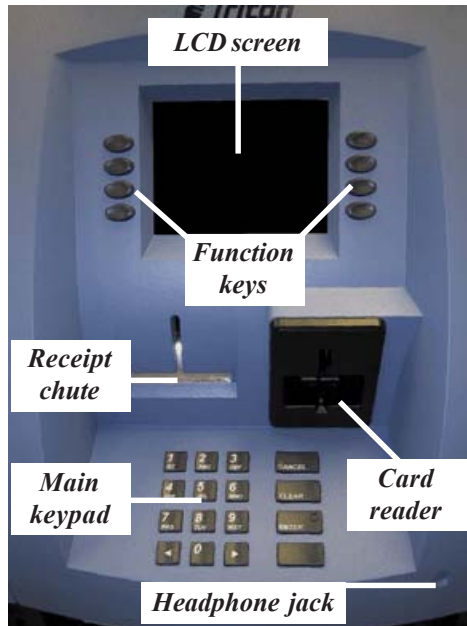

Figure 2-1. Control panel layout.



## BASIC OPERATION

### FUNCTION KEYPADS

The primary menu navigation keys, called Function keys, are arranged in two four-key groups, one group on either side of the LCD screen. A Function key is only active when a function or menu option name is displayed (if the display is “grayed out”, that option is not available). The Function keys are designated F1 through F8, as shown in Figure 2-2.

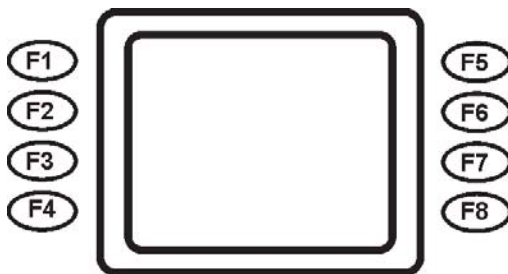

Figure 2-2. Function key layout.

### MAIN KEYPAD

The entry of numeric characters via the main keypad is straightforward: simply press the desired key. However, in certain Management Function screens it may be necessary to enter alphabetic characters, a procedure that requires a little more explanation. On such screens, a flashing cursor will be evident on the display, representing the location where the next character you enter will be displayed. To enter a letter or punctuation mark, you will first press the <CTRL> key (the blank key in the lower right-hand corner of the keypad), and then you will press the number that has the letter or other character you want.

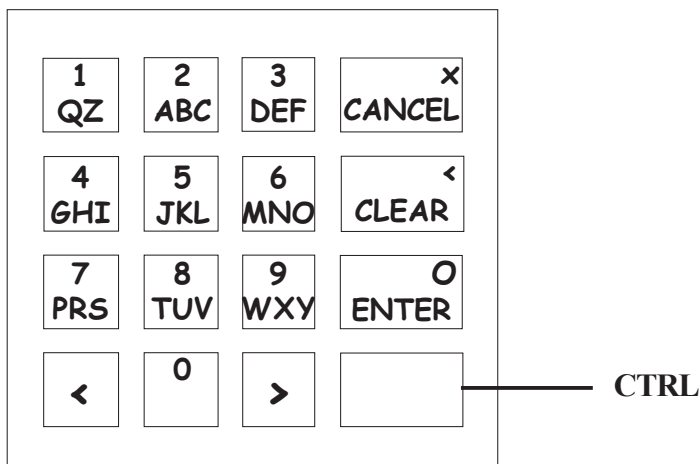

Figure 2-3.  
Alphanumeric  
keypad.

## MODEL 9100 USER MANUAL

Each of the numbered keys (<0> through <9>) has six characters available. See Table 2-1, Keypad characters. On most of these keys (<2> through <9>), the first three of the available characters are alphabetic, and are printed on the keycap above the number character. Two keys, the <0> and <1>, are different. The <0> key does not show any additional characters, while the <1> key shows two alphabetic characters ('QZ').

TABLE 2-1 - KEYPAD CHARACTERS						
	X1	X2	X3	X4	X5	X6
1	Q	Z	Space	~	!	@
2	A	B	C	#	\$	%
3	D	E	F	^	*	_
4	G	H	I	(	)	
5	J	K	L	\	/	"
6	M	N	O	;	:	' Single Quote (Open)
7	P	R	S	?	<	>
8	T	U	V	[	]	ñ
9	W	X	Y	{	}	' Single Quote (Close)
0	,	.	-	&	=	+

*Table 2-1. Keypad characters.*

The first character on the first key (0-9) you press after the <CTRL> key will be displayed at the current cursor position. Pressing the same key repeatedly (X1-X6) will cycle the displayed letter through the available character choices for that key.

When the desired character is displayed, press the <RIGHT ARROW> key to 'lock it in' and move the cursor to the next position. Repeat these steps to enter the next character.

The <RIGHT ARROW> and <LEFT ARROW> keys are used in most alphanumeric data entry situations. The <LEFT ARROW> is used to back up and erase a character. The <RIGHT ARROW> is used to lock in a character. These keys will auto-repeat if held down for more than one second.

The <CLEAR> key can be used to clear an entry and start over. The <CANCEL> key will abort the current transaction.

## BASIC OPERATION

---

### MENU-BASED OPERATION

The terminal operates as a menu driven system. Messages and menu options presented on the LCD display screen guide the user's actions. The desired menu option is selected by pressing one of the keys located to the left and right of the display. For the purpose of security many screens timeout after a preset time interval, usually 30 seconds. The timeout length may vary depending on the function being performed.

When a screen timeout occurs, a screen is presented which asks the user if more time is needed. If the user chooses NO, the Customer Welcome screen will be presented. If YES is chosen, the user is returned to the function that was active prior to the timeout. If the user does not make a selection within an additional 30-second countdown period the terminal will automatically go to the Customer Welcome screen.

When the unit is turned on, the dispenser will beep once and the Top menu, shown in Figure 2-4, will appear on the display screen after a few seconds. From the Top menu, you can either:

1. Activate the terminal to perform customer transactions by pressing the key next to CUSTOMER TRANSACTIONS.
2. Enter the terminal system management area by pressing the key next to MANAGEMENT FUNCTIONS.  
*Note: You will have to enter an appropriate password to view the Management Functions menu.*

If you do not select a menu choice within 30 seconds the terminal will automatically default to the Customer Welcome screen (a benefit of this feature is that in the event of a power interruption the terminal will automatically begin accepting customer transactions shortly after power is restored).



Figure 2-4. Top menu screen.

## CUSTOMER TRANSACTIONS

A customer begins a transaction by selecting from the Customer screen options. They insert their ATM card into the card reader of the terminal. The card must be inserted so that the magnetic stripe can be scanned by the card reader's sensor. If the customer inserts the card incorrectly, a warning message will be displayed, accompanied by several beeps to get their attention.

If there is a problem reading a card, make sure the customer is inserting the card correctly. Most problems are the result of inserting the card incorrectly.

Once the card has been read in successfully, a surcharge message, if applicable, may be displayed (the surcharge message may be displayed at the end of the customer's transaction selection). The customer must then enter their secret Personal Identification Number (PIN) code. Once the PIN has been entered, the transaction type and account are selected, and the desired amount of the transaction, if needed. The transaction will be processed, typically in a matter of seconds.

Figure 2-5 shows how ATM transactions are handled. If the transaction was processed successfully, the customer is prompted to retrieve the requested cash (for withdrawal transactions) and/or the applicable transaction receipt, as needed. If the transaction was declined, a short receipt indicating the problem is printed.

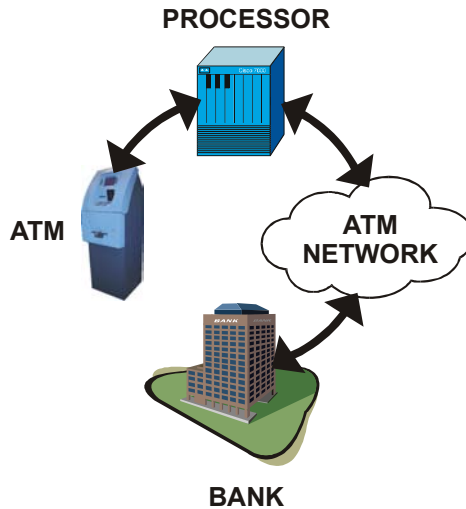

Figure 2-5. ATM transaction processing.

## BASIC OPERATION

---

The ATM sends the customer transaction request to a processor. A processor is a financial intermediary, such as an Independent Sales Organization (ISO), bank, or other financial institution that provides transaction-processing services for ATMs. The ATM must be set up with a particular processor before customer transactions can take place.

The processor routes the transaction to the appropriate ATM network. An ATM network is a regionally or nationally organized clearing house for financial transactions, that deals directly with the appropriate financial institution, such as the customer's bank or credit card company, in order to complete the transaction. The processor will select the appropriate ATM network to use based on factors such as the type of ATM or credit card used, location of the customer's bank, or other considerations. The transaction may be transferred between several networks before ultimately reaching the customer's bank or credit card company.

The ATM network routes the transaction to the appropriate bank or other institution, confirms successful completion of the transaction, and sends a confirmation message back to the processor. If the request was for a cash withdrawal, an Electronic Funds Transfer (EFT) takes place to debit the funds (including any surcharge fee, if applicable) from the customer's bank account and credit the funds to the processor's bank account.

The processor forwards a confirmation message to the ATM (and an authorization to dispense currency, in the case of a cash withdrawal). The ATM dispenses the requested currency, if necessary, and provides the customer with a printed receipt as a record of the transaction.

The processor credits the merchant's account for the amount of any cash withdrawals (plus surcharge fees, if collected), typically by the end of the next business day).

### VOICE-ENABLED TRANSACTIONS

The terminal provides voice feedback via an integrated output jack, enabling sight-impaired users to plug in a set of headphones and receive spoken instructions to assist them in using the ATM (Figure 2-6).

A raised symbol helps a user locate the headphone jack. The ATM will automatically detect when a headphone has been plugged into the jack, and will immediately switch into voice mode. Initially, a brief spoken tutorial will orientate the customer to the ATM control panel interface. Once the customer begins a transaction, spoken prompts will provide feedback and guide the customer through the successful accomplishment of the transaction.



*Figure 2-6. Headphone jack location.*

# SECTION 3

## MANAGEMENT FUNCTIONS



## INTRODUCTION

This section describes the Management Functions available with the ‘MASTER’ password for accessing the ATM. When the Customer Welcome screen is displayed, you can access the Management Functions menu by following the procedure described next.

### ACCESSING THE MANAGEMENT FUNCTIONS MENU

1. Press and hold down the <CTRL> key; while holding down the <CTRL> key, press the <1> key. Release both keys. After a moment the top menu will be displayed.
2. At the top menu, select MANAGEMENT FUNCTIONS by pressing the key next to Management Functions option.
3. Enter the user password at the password entry display.

### CHANGE DEFAULT PASSWORDS

**A new error code (246) has been created for when the terminal’s MASTER and/or ADMINISTRATION password(s) are in the default state. The terminal will detect this condition and go out of service. On the “Out of Service” screen, no error information will be displayed. This error code will not reset until the Master and/or Administration passwords are changed from their default state.**

**The default MASTER password is ‘123456’ and the default ADMINISTRATION password is ‘987654’.**

***\* IMPORTANT \****

***NEVER USE THE IDENTICAL PASSWORD FOR BOTH MASTER AND ADMINISTRATION!***



*Main menu screen (multihost).*

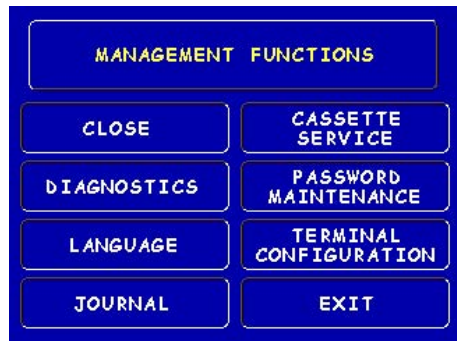

*Figure 3-1. Main menu screen (non-multihost).*



### Software Updates

There are Supplements at the back of this document that describe new/changed Management function features. Refer to your particular countries version for information regarding these updates.

### NEW OR MODIFIED MANAGEMENT FUNCTIONS

The majority of the Management Functions are configured the same as before but they may have been relocated in the menu structure. A brief synopsis of each function is provided. A summary of the changes to the Management Functions is provided below:

☞ **MAIN MENU** - Three (3) major configuration paths now exist: Terminal, Services, and Processors. The other options (Cassette Service, Diagnostics, Close, and Journal) have moved slightly but their functions remain the same.

☞ **DIAGNOSTICS** - To reset an on-screen VEPP tamper error '205' or VEPP Serial number error '239', you must traverse through the Diagnostics menu items. A new option, "**KEYPAD**", allows user to clear either of these 2 error codes.

☞ **Key Management** - Two (2) passwords are now required before users can enter the PIN Master keys option. Once accessed, two (2) key parts (32 number/character stream) must be loaded, followed by a second part. The Check Digits are displayed before either accepting or declining. An on-screen keypad directs users for entering numbers and characters.

☞ **COMMUNICATION** - This menu item replaces the Telephone Configuration. TCP/IP configuration setup is now included with the Modem setup.

☞ **TRITON CONNECT™** - Moved under "ATM Monitoring". TCP/IP configuration setup also included for Triton Connect. The communication type (dial-up or TCP/IP) is automatically detected.

☞ **CONFIGURE PROCESSORS** - Processor specific information is now configured under this option. Standard ATM cash transactions **WILL** use processor number one (1) as its default. Processors 2 through 4 reserved for future applications.

☞ **SURCHARGE** - You may now block up to one hundred (100) ISOs at the terminal.

☞ **UPDATING SOFTWARE.** When installing an update file over any prior software release on a terminal with a TDM100 or TDM150 dispenser, the cassette multiple amount (value) will need to be reconfigured before the terminal will go into service. You will only have to configure one time after you update. Any other future releases will not require configuring amount values.

### Cassette Service

**Multi-Cassette Dispensers:** During the initial boot procedure, the terminal may force an **Error Code 156** to ensure the user enters the Cassette Setup functions to configure and put at least one cassette "**In Service**".

**MAIN MENU**

**ACCESS INSTRUCTIONS:**

1. Access Management Functions by entering your password. The **MAIN MENU** screen will be displayed.

**DESCRIPTION:**

The **Main Menu** screen allows the service provider/terminal operator to access the following Management functions:

1. **Configure Terminal.** Used to configure operating parameters for the ATM terminal.
2. **Configure Services.** Used to select transaction types, account types, and surcharging setup.
3. **Configure Processors.** Used to configure up to four (4) Host/Processor specific parameters.

*\* Note: Processor #1 **MUST** be configured for ATM cash transactions. Configure the processor prior to Configuring Services.*



4. **Cassette Service.** Allows the desired cassette(s) to be placed **IN SERVICE**.
5. **Diagnostics.** This function performs self-tests on the major components to help determine and isolate any malfunctions or errors.
6. **Close.** Used to perform Cassette Close, Day Close, Trial Close, and Schedule Close functions.
7. **Journal.** Journal data is imbedded in the dispenser firmware. The details of each transaction are stored in the journal's memory and can be retrieved at a later date. When needed, just the information desired can be recalled and a printout of the records made.

**Note**

In configuring the parameters, the availability of some options may be “grayed out” due to the specific dispensing mechanism installed or other features.

## CONFIGURE TERMINAL

### ACCESS INSTRUCTIONS:

1. From the **MAIN MENU** screen, select **CONFIGURE TERMINAL**.

### DESCRIPTION:

The following options will be available from the **CONFIGURE TERMINAL** screen:

1. **Cassette Setup.** Allows the terminal operator to view and change cassette parameters.
2. **Date/Time Functions.** Provides a menu related to configuration of date and time parameters
3. **Language Idioma.** Provides access to the options that control the language that is displayed on the ATMs LCD display.
4. **Printer Settings.** Provides access to printer receipt length, low paper acknowledgment, and graphics.
5. **ATM Monitoring.** Allows **Triton Connect™** setup and enabling, heartbeat messaging, and alarm thresholds.
6. **Password Maintenance.** Allows access to menus for viewing and changing the Master and Administrative passwords.
7. **More.** Additional options for couponing, messaging, etc. A listing of items are covered on the next page.



**CONFIGURE TERMINAL  
(MORE)**

1. **AD Screens.** This feature enables or disables the display on an idle terminal to alternate between the Welcome Screen and a screen containing graphics and text elements used to make an advertisement screen.
2. **Random/Level Prize Coupons.** Provides access to setup terminal operations for issuing printed and dispensed prize coupons.
3. **Change Messages.** Allows information for various terminal and receipt messages to be changed or authored.
4. **Communication.** Allows modem and/or TCP/IP parameters to be configured and tested.
5. **Adjust Contrast.** Adjusts the contrast of the display. *\*Note: This function not available in Model 8100/9100 ATMs. A manual adjust is located on the units Main board.*
6. **Local Zip Code.** Allows entry of the zip code where terminal is located.
7. **More.** Two (2) more additional options; Speech and View/Modify.



1. **Speech On/Off.** Enables/disables the voice-activated headphone jack.
2. **View/Modify Options.** Allows access for setting a selected feature.



CASSETTE SETUP

ACCESS INSTRUCTIONS:

1. From the **MAIN MENU** screen, select **CONFIGURE TERMINAL**.
2. From the **CONFIGURE TERMINAL** screen, select **CASSETTE SETUP**.

DESCRIPTION:

The following options will be available from the **CASSETTE SETUP** screen:

1. **Relearn Bill Thickness.** Enables you to force the dispenser to enter the learning mode (*TDM-family dispensers*).
2. **International Currency.** Allows operator to select one of (128) pre-defined characters as possible monetary symbols that describe the type of currency being used.
3. **Maximum Amount (Cash).** Allows operator to set the maximum amount withdrawal limit. The maximum amount cannot be more than fifty (50) times the denomination value in the cash dispenser.
4. **Maximum Amount (Non-Cash).** Allows operator to set maximum non-cash purchase limit for non-cash items. *\* Note: This function applies to NMD-family dispensers only!*
5. **Cassette Parameters.** Used to perform cassette-specific configuration and setup operations.
6. **Fast Cash Amounts.** These amounts are entered by operator to prompt customer to select five (5) convenient amounts. The amounts must be multiples of the denomination(s) in the cassette(s).
7. **More:** Two (2) more additional options; Low Currency and Extended Amounts.
  1. **Low Currency.** Used to enable/disable low currency checking on the dispenser mechanism. *\*Note: Available with units that have an SDD 1700 dispenser mechanism installed.*
  2. **Extended Amount.** Extends the currency amount entry field from eight (8) to twelve (12) digits, if needed.

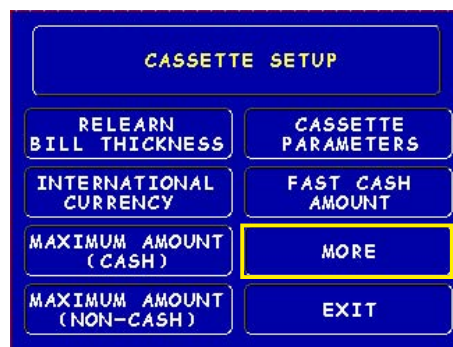
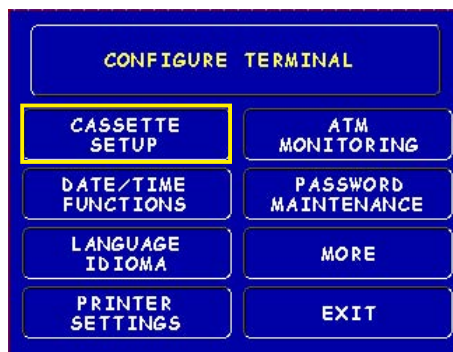

CASSETTE PARAMETERS

ACCESS INSTRUCTIONS:

1. From the CONFIGURE TERMINAL screen, select CASSETTE SETUP.
2. From the CASSETTE SETUP screen, select CASSETTE PARAMETERS.
3. Select CASSETTE “A”, “B”, or “C” (cassette “D” will be grayed out).



DESCRIPTION:

The following options will be available from the CASSETTE SETUP screen:

1. **Set Bill Dimensions.** *Note: Does not apply for TDM dispensers.*
2. **Value.** Allows the operator to set the value of a cash or non-cash item in a particular cassette. Value is the denomination of the currency or face value of the particular non-cash item.
3. **Type.** This describes the item in the particular cassette: “Cash” or “Non-Cash”. Default is “Cash”.
4. **Service.** This function displays the current cassettes status and provides the option to place a cassette either **IN SERVICE** or **OUT OF SERVICE**.  
*Note: Multi-cassette TDM dispensers only.*
5. **Currency Data.** *Note: Does not apply for TDM dispensers.*
6. **Cassette.** Allows you to select another cassette, if applicable.
7. **Description.** Provides access to menus that let the operator enter a brief description of **non-cash** only items in a cassette (*Applies to NMD-family dispensers only!*).

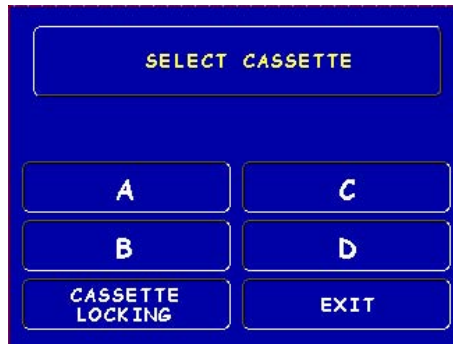

**\*Note\***

- Cassette “A” is for single cassette dispensers.
- “CASSETTE LOCKING” feature does not apply.

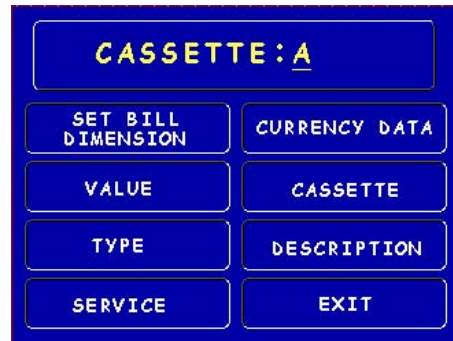

**CONFIGURE PROCESSORS**

**ACCESS INSTRUCTIONS:**

1. From the **MAIN MENU** screen, select **CONFIGURE PROCESSORS**.
2. From the **CONFIGURE PROCESSORS** screen, select option **(1)**.

**\*\* Important\*\***

**Option (1) MUST be configured. It is the default processor for standard ATM transactions.**

**DESCRIPTION:**

The following options will be available from the **CONFIGURE PROCESSORS** screen:

0. **Processor Name.**
1. **Terminal ID.**
2. **Key Management.**
3. **Communication Type.**
4. **Communication Numbers.**
5. **Send Terminal Totals.**
6. **Status Monitoring.**
7. **EOT (End Of Transmission).**
8. **Communications Header.**
9. **Predial.**

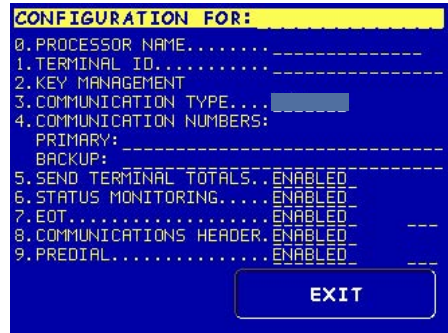
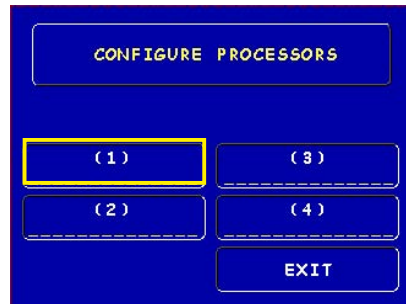

CONFIGURE PROCESSORS

Option 0. Processor Name



**Processor Name.** Allows entry for the name of the specified processor (Ex: CALYPSO)

Option 1. Terminal ID

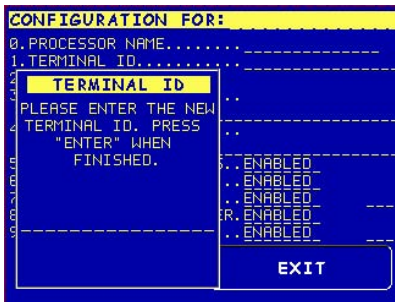

**Terminal ID.** Allows entry of the terminal ID assigned by the host processor.

Option 2. Key Management



**Key Management.** Allows entry of the PIN Master key(s) assigned by the host processor.

Option 3. Communication Type

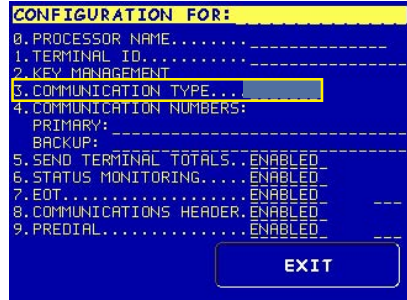

**Communication Type.** Allows user to toggle between the communication type the terminal is using (Dial-up, TCP/IP). *Note: Models 8100/9100 auto detect the communication type installed and will not allow user to change (toggle).*

Option 4. Communication Numbers



**Communication Numbers.** Allows entry of the host processors primary and backup (if needed) phone numbers or the Host TCP/IP/ addresses if running that communication type.



## CONFIGURE PROCESSORS

The remaining options are toggled to either ‘**Enable**’ or ‘**Disable**’ that particular function.

**Send Terminal Totals.** When this option is Enabled, the terminal will send accumulated totals information to the processor during the close operation.

**Status Monitoring.** Status monitoring is a feature available with selected processor software. When Enabled, the terminal will send operational status information to the processor. The status information is sent in a data field that is part of any of the following messages:

- A transaction request message.
- Comms key download.
- Host totals download request.
- Reversal request message.

**EOT (End Of Transmission).** When this option is Disabled, the terminal will not look for the EOT character at the conclusion of the transaction. Contact your host processor to verify before Enabling. This option is processor-specific.

**Communications Header.** This optional feature is only applicable to certain processors. When required, it must be Enabled and have the correct data in the header data field. The Communication Header consists of alphanumeric characters.

**Predial.** When this feature is Enabled, the terminal will dial out to the processor and establish a connection as soon as the customer’s ATM or credit card has been scanned by the card reader.

### Options 5-9. Toggled (Enable/Disable)

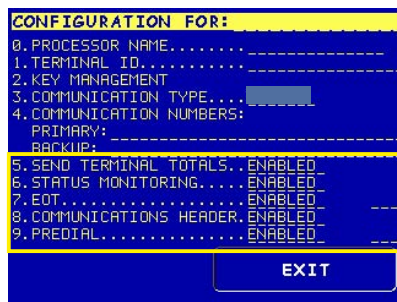

**\*\*Warning\*\***

Enabling the **COMMUNICATION HEADER** when using a processor that doesn’t use this feature will prevent any type of transaction from completing. Disabling or having incorrect data in the **COMMUNICATION HEADER** data field (if the feature is required) will also prevent any type of transaction from processing

**KEY MANAGEMENT**

**ACCESS INSTRUCTIONS:**

1. From the **MAIN MENU** screen, select **CONFIGURE PROCESSORS**.
2. From the **CONFIGURE PROCESSORS** screen, select option **(2)** for **KEY MANAGEMENT**.

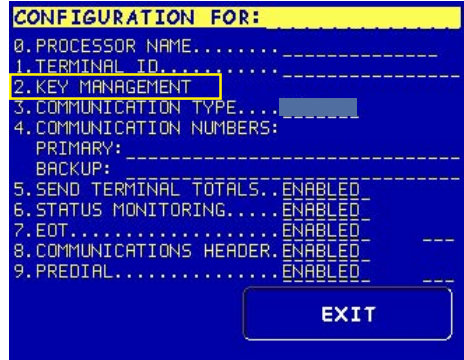

**DESCRIPTION:**

The **KEY MANAGEMENT** function provides access to the ATMs functions that control the method of entry for MAC Master Keys and/or PIN Master Keys, downloading the PIN Working Keys, and displaying the Check Digits. The new VEPP requires that two key parts for each key are loaded. After this screen will be a screen to indicate that the second part must be entered. Then the “**Enter**” function key will be displayed to load the second key part. After the second key part is loaded, the terminal will prompt if any additional key parts need to be loaded.

**\* Important\***

Before proceeding, check to ensure there are no VEPP Tamper (EC 205) or VEPP Serial Number (EC 239) errors. **You must clear these errors first!** To check/clear the errors, enter **MANAGEMENT FUNCTIONS > DIAGNOSTICS > MORE DIAGNOSTICS > MORE (MORE) DIAGNOSTICS > KEYPAD**. Failure to clear these errors first will decline entry of DES keys.

The following sequence will be displayed from the **KEY MANAGEMENT** screen:

1. **Enter Master Keys** - Select this option to enter the encryption keys.  
**Download Working Keys** - Select this option to download the Working Keys (**Must** be selected after entering PIN and/or MAC Master keys).  
**Check Digits** - Displays encryption key check digits.



## MANAGEMENT FUNCTIONS

2. **Password Required** - When “Enter Master Keys” is selected, you will be prompted to enter two (2) passwords. If this is an initial setup, the default password is **six (6) zeros (000000)** for each. You will then be prompted to change passwords. Passwords **MUST** be changed!



3. **Change Password (Initial Setup)** - The VEPP requires that no default password can be entered. If a user enters the default password, the VEPP will force the user to change them before they can enter keys.



4. **Change User Passwords (cont)** - This screen allows the user(s) to select which password to change. If any password is the default value, the VEPP will only allow these two functions to be selected.



5. **Change User Passwords (cont)** - If this is an initial setup, the current password will be six (6) zeros (000000). Enter a new password (twice). A password consists of six (6) numbers, no characters. A screen prompt will appear if the passwords was changed successfully. **DO NOT** use weak passwords (Ex: 111111,123456)



6. **Enter Master Keys** - This screen allows selection to enter the Master keys. You **MUST** enter PIN Master keys. **DO NOT** enter keys in the MAC Master keys unless processor directs. You **MUST** enter two (2) sets of keys (32 alpha/numerical).



7. **Enter Keys** - Enter the first (32) alpha/numerical key. The on-screen keypad legend describes the ATMs keypad for entering numbers and characters. Select "ENTER" using the display function key.



8. **Check Digits** - After selecting "Enter" from previous screen, you will get the Check Digit which you can either Accept or Decline. When you "Accept" the key check digit, enter the second key. After accepting the second key part, you will be prompted "Another Key Part". Select "Yes" if a third key is needed or "No" if none.



9. **Download Working Keys** - After entering the keys, exit out to the Key Management Main screen and Download Working Keys. You **MUST** download the Working keys from the processor.



## CONFIGURE SERVICES

### ACCESS INSTRUCTIONS:

1. From the **MAIN MENU** screen, select **CONFIGURE SERVICES**.

### DESCRIPTION:

The following options will be available from the **CONFIGURE SERVICES** screen:

1. **STD ATM Configuration.** This option allows configuration of the types of services for normal customer transactions.
2. **PaySpot Configuration.** This option allows configuration of cellular and long-distance services.  
**(NO LONGER SUPPORTED)**
3. **CashWorks Configuration.** This option allows configuration of maximum check cashing amounts.  
**(NO LONGER SUPPORTED)**
4. **Western Union Configuration.** This option allows configuration of note denominations loaded in the dispenser mechanism and account types.  
**(NO LONGER SUPPORTED)**

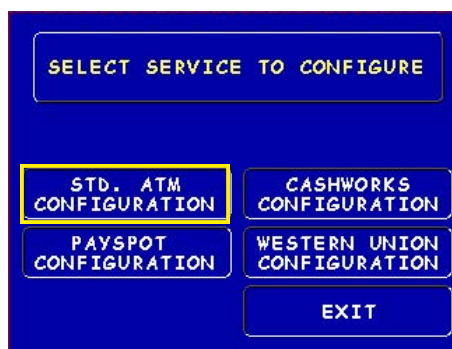

\*Note\*

STD ATM Configuration uses the default processor number one (1). You **MUST** configure processor number (1) for standard terminal operations.

**STD ATM CONFIGURATION**

**ACCESS INSTRUCTIONS:**

1. From the **MAIN MENU** screen, select **CONFIGURE SERVICES**.
2. From the **CONFIGURE SERVICES** screen, select **STD. ATM CONFIGURATION**.

**DESCRIPTION:**

The following options will be available from the **STANDARD ATM CONFIGURATION** screen:

1. **Transaction Types.** This function allows turning **ON** or **OFF** the availability of two (2) transaction types: **Transfers** and **Balance Inquiries**. It also allows prompting the customer on balance inquiries.
2. **Account Types.** Allows turning **ON** or **OFF** the availability of two (2) account types: **Savings** and **Credit Card**.
3. **Surcharge.** This function allows operator to set surcharging configurations.

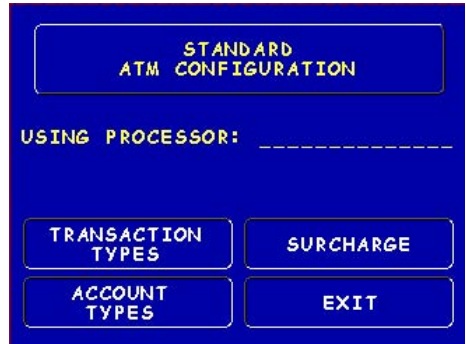
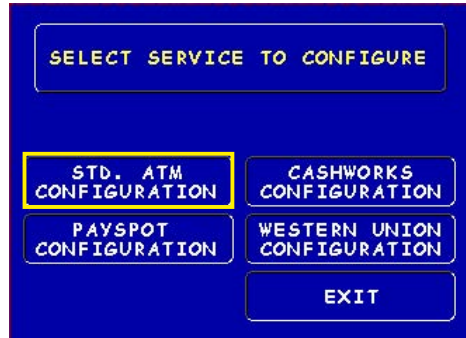

**\*Note\***  
 The Using Processor defaults to processor number one (1) in the Configure Processor setup. You can not change the processor.

## CASSETTE SERVICE

### ACCESS INSTRUCTIONS:

1. From the **MAIN MENU** screen, select **CASSETTE SERVICE**.

### DESCRIPTION:

The **CASSETTE SERVICE** function allows the operator to put the selected cassette(s) “**In Service**” or “**Out of Service**”. This function can also be used to clear **Error Code 156, Cassette Out of Service**.

*Note: For single cassette dispensers, cassette “A” is automatically “In Service”.*

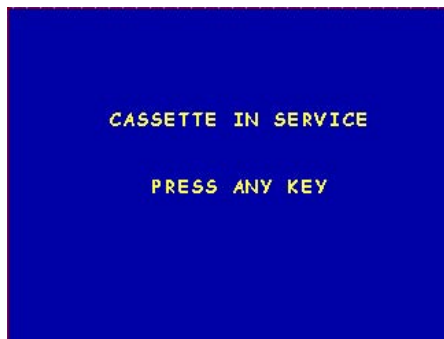
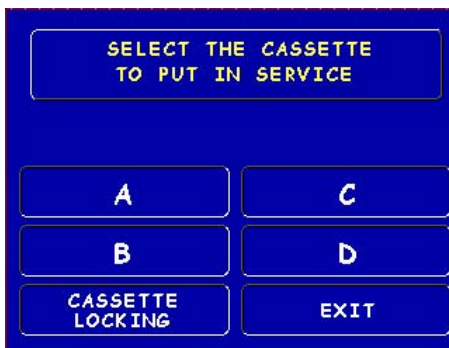

**DIAGNOSTICS**

**ACCESS INSTRUCTIONS:**

1. From the **MAIN MENU** screen, select **DIAGNOSTICS**.

**DESCRIPTION:**

The following options will be available from the **DIAGNOSTICS** screen:

1. **Status.** This function presents the status checks on the primary functional areas of the dispensing mechanism.

2. **Purge.** This function instructs the dispenser to remove all documents from the feed path. The return code for a successful purge in a single cassette dispenser is '20 20 20'. The return code for a multi-cassette dispenser is '0'.

3. **Test Dispense.** This function instructs the dispensing mechanism to dispense one (1) note from the cassette into the reject cassette/compartments.

**(TDM installed)** A return code in a single cassette dispenser of '20 1 0 0 0' indicates a successful test dispense (20) and (1) note picked from cassette A.

**(SDD/Minimech)** A return code in a single cassette dispenser of '20 20 21' indicates a successful test dispense (20) and (1) note picked from the cassette.

4. **Format Graphic Memory.** This function erases the memory used to store AD graphics. AD graphics can then be downloaded from a local terminal or through Triton Connect.
5. **Test Receipt Printer.** This function tests the operation of the receipt printer and prints out configuration parameters, processor setup, etc, that may be used to verify terminal setup.
6. **Version #'s.** This function displays the version numbers of the terminal operating software.
7. **More Diagnostics.** Accesses additional diagnostic functions.





**MORE DIAGNOSTICS**

**ACCESS INSTRUCTIONS:**

1. From the **MAIN MENU** screen, select **DIAGNOSTICS**.
2. From the **DIAGNOSTICS** screen, select **MORE DIAGNOSTICS**.

**DESCRIPTION:**

The **MORE DIAGNOSTICS** menu allows the terminal operator to perform the following functions:

1. **Inject New Cassette ID.** This function enables the user to change the identification code of a cassette.  
*\*Note: For NMD multi-cassette dispensers only.*
2. **Communication.** This function performs a function test of the modem or TCP/IP hardware. This does not test the ability of the modem or TCP/IP device to communicate with the phone/data line.
3. **MODEM SPEAKER ON/OFF.** Allows speaker sound on or off.
4. **FORCE UNLOCK.** This function provides a means of overriding the unlocking mechanism associated with a particular cassette. It is to be used immediately after failure of a normal cassette unlock operation.  
*\*Note: For NMD multi-cassette dispensers only.*
5. **PRINT DISPENSER STATUS.** This function prints the “TDM Status” report. This report provides useful information that can assist a service technician. *\*Note: Available when a TDM dispensing mechanism is installed.*
6. **CLEAR DISPENSER STATUS.** This function resets the count in the “Since Reset” column on the dispenser data report.  
*\*Note: Available when a TDM dispensing mechanism is installed.*
7. **MORE DIAGNOSTICS.** Accesses additional diagnostic functions.
8. **PREVIOUS.** Returns user to main diagnostics screen.

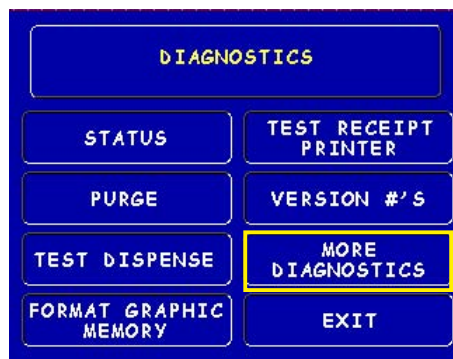

**MORE (MORE) DIAGNOSTICS**

**ACCESS INSTRUCTIONS:**

1. From the **MAIN MENU** screen, select **DIAGNOSTICS**.
2. From the **DIAGNOSTICS** screen, select **MORE DIAGNOSTICS**, then select **MORE DIAGNOSTICS** again.

**DESCRIPTION:**

The **MORE (MORE) DIAGNOSTICS** menu allows the terminal operator to perform the following functions:

**Note: VEPP errors MUST be cleared before attempting to enter Master keys.**

1. **Keypad.** This function enables the user to reset VEPP errors that appear on the terminal screen (**Error Code (EC) 205 and/or 239**). It also provides a status of the VEPP device which can be printed.
  - **Clear Tamper.** Allows user to reset a tamper condition if exists (**EC-205**).
  - **Clear Serial Tamper.** Allows user to reset a serial number tamper condition if exists (**EC-239**).
  - **Status.** Allows user to view/print the VEPP device status.
2. **Scan Card.** Enables testing an ATM or credit card for proper operation in the terminal card reader.

**Key Status A-D refers to multi-host processors key information.**

KEY STATUS	
00	No Keys Loaded
02	PIN Master Key Loaded
03	PIN Master/MAC Master Keys Loaded
14	PIN Master Key Loaded PIN Working Key Downloaded
36	PIN Master/MAC Master Keys Loaded PIN Working/MAC Working Keys Downloaded

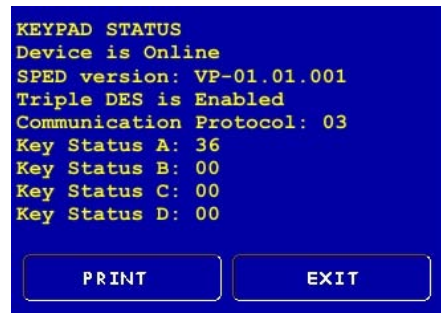
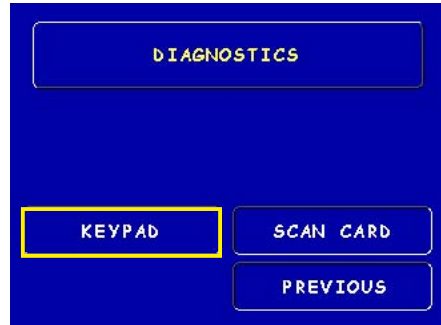

CLOSE

ACCESS INSTRUCTIONS:

1. From the **MAIN MENU** screen, select **CLOSE**.

DESCRIPTION:

The following options will be available from the **CLOSE** screen:

1. **Schedule Close.** This function allows you to turn **ON/OFF** the schedule close feature. It also provides access to specify the time of day when a **DAY CLOSE** process is initiated.
2. **Trial Close.** This function is used to get the totals from the ATM. It prints information from the processor and the terminal itself. It functions like a **Day Close** except the totals are not cleared.
3. **Day Close.** This function is used to complete daily balancing of the ATM with the processor. The printed information includes a total of all transactions. The totals are cleared and switched to the next business day.
4. **Trial Cassette Close (All).** This function prints a receipt summarizing activity on all cassettes since the last **Cassette Close** was performed. The totals are not cleared or reported to the processor.
5. **Cassette Close.** This function is used to access menu options for cassette close and replenishment actions.



CASSETTE CLOSE

ACCESS INSTRUCTIONS:

1. From the MAIN MENU screen, select CLOSE.
2. From the CLOSE screen, select CASSETTE CLOSE.

DESCRIPTION:

The following options will be available from the CASSETTE CLOSE screen:

**Select Cassette.** This option allows the operator to select cassette-specific close operations. *Note: Single cassette dispensers default to cassette "A".*

1. **Trial Cassette Close.** Prints a receipt summarizing activity on the selected cassette since the last Cassette Close was performed (Totals are not cleared or reported to the host).
2. **Cassette Close.** This function is used to complete the balancing of the specified cassette. It prints a report summarizing all activity on the selected cassette since the last **Cassette Close** and clears the totals. It also resets the number of bills in the cassette to zero (0).
3. **Select Cassette.** Allows operator to switch between cassettes when performing cassette close operations. *Note: Cassette "D" will be grayed out.*
4. **Enter Qty. in Cassette.** This option allows entry of the number of notes/documents in the cassette. This number is used as the starting point for the cassette close report.

*\*Note: Enter the total number of notes placed in the cassette, NOT the value of the currency.*

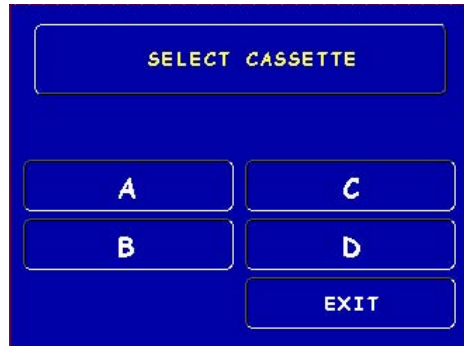
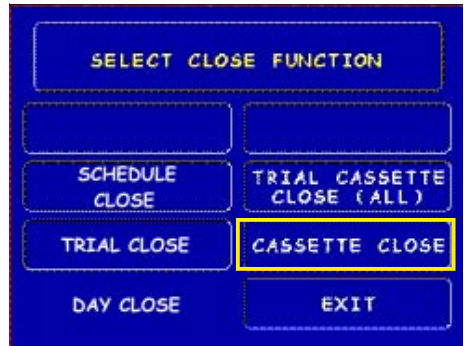

## JOURNAL

### ACCESS INSTRUCTIONS:

1. From the **MAIN MENU** screen, select **JOURNAL**.

### DESCRIPTION:

The following options will be available from the **JOURNAL** screen:

1. **Print Journal.** This function is used to automatically print out any journal entries collected since the last time the journal was printed. All *unaudited* records are printed and marked as *audited*.
2. **Clear Journal.** This function is used to mark all unprinted records as *audited*. They will not be printed out when a Print Journal command is performed.
3. **Print Last X Entries.** This function is used to retrieve *audited* and *unaudited records* from the journal, either before or after they have been Printed or Cleared.

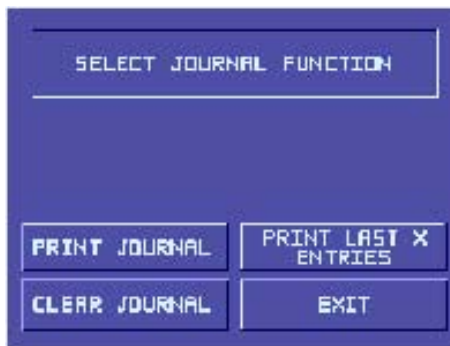
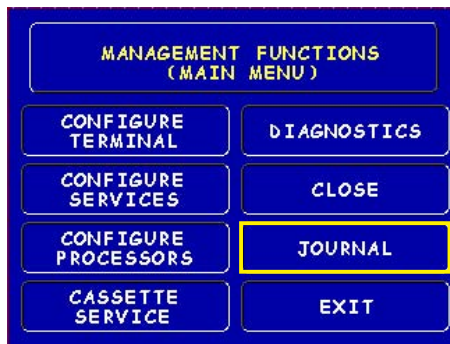

### \*Note\*

The Electronic Journals (EJ) buffer can store up to 2045 entries. If you have an *external EJ* (units with an SDD or Minimech dispenser), you may retrieve the last **2045** entries using the Print Last X command.

The TDM dispenser mechanisms installed have an imbedded memory chip that holds the journal entries. You may retrieve the last **1024** entries using the Print Last X command.

**THIS PAGE INTENTIONALLY LEFT BLANK**

# TCP/IP (ETHERNET) CONFIGURATION

### INTRODUCTION (TCP/IP ETHERNET)

This section will discuss the TCP/IP Ethernet-specific Management Functions. The Ethernet hardware should be previously installed. In the 8100/9100 models, only one communication type is allowed for all hosts.

#### TCP/IP ADDRESSES

The Ethernet-equipped ATM communicates using Transmission Control Protocol (TCP) and Internet Protocol (IP), allowing it to send and receive information in the form of small packets of digital data. In order to configure the ATM to correctly access the host network using this protocol, IP addresses must be entered into the appropriate ATM setup functions. The Addresses are the **HOST TCP/IP**, **TERMINAL IP**, **SUBNET MASK**, **GATEWAY**, and **LISTENING PORT**.

The addresses are attached to the data packet that is being sent; the **HOST TCP/IP** address allows the data packet to be routed through the TCP/IP Ethernet network, ultimately to be received and processed by the host server on the network. The **TERMINAL IP** address identifies the ATM as the source of the data packet, and is used by the host server to return acknowledgements, transaction approvals, or other data to the ATM. Alongside the addresses, each port requires a **SUBNET MASK**.

This part of the IP address distinguishes other machines on the same LAN from machines in other departments or elsewhere in the world. For direct access to networks beyond the current one, each machine must be told the IP addresses of the router (or **GATEWAY**) that connects the local network with the wider world. The **LISTENING PORT** value identifies the data being sent to that specific machine. The **MAC ADDRESS** is assigned from the iChip manufacturer. The **CHIP VERSION** indicates the chip family, software version, and boot block revision in the Ethernet device only. **TCP/IP TIMEOUT** is the time that the terminal will wait from the message to be sent to the host and the time it takes for the host to respond.

If Triton Connect ATM monitoring software is being used, the applicable IP addresses for the Triton Connect host computer and Alarm Monitoring feature must also be entered.

The descriptions on the following pages will cover how to access the appropriate functions and initially enter the IP addresses and any other TCP/IP Ethernet operating parameters or diagnostics.



**CONFIGURE PROCESSORS  
COMMUNICATION TYPE**

**ACCESS INSTRUCTIONS:**

1. From the **MAIN MENU** screen, select **CONFIGURE PROCESSORS**.
2. From the **CONFIGURE PROCESSORS** screen, select option **(1)**.
3. From the **CONFIGURATION FOR:** menu screen, select option **(3)**.

**\*\* Important\*\***

**Option (1) MUST be configured. It is the default processor for standard ATM transactions.**

**DESCRIPTION:**

The **COMMUNICATION Type** function allows user to toggle between the communication type the terminal is using. You can select either Dialup, Wireless, or TCP/IP. **The External Ethernet option must be installed to select.**

**Note: (Model 8100/9100 ATMs)**

**This function detects the communication type installed and WILL NOT allow user to change (toggle). It also sets the communication type for Triton Connect**

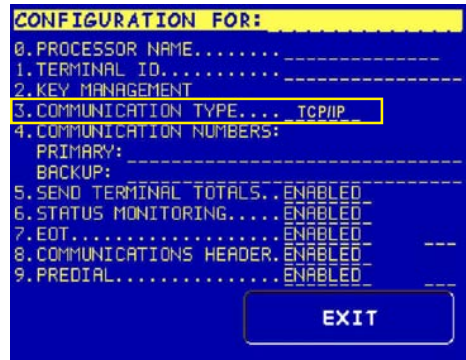
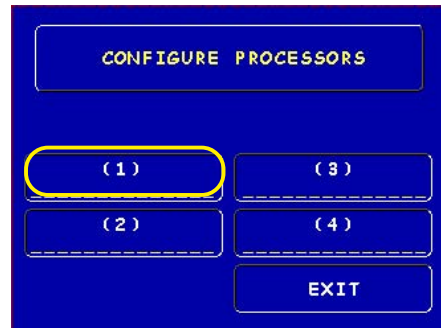

## COMMUNICATION NUMBERS

### ACCESS INSTRUCTIONS:

1. From the **MAIN MENU** screen, select **CONFIGURE PROCESSORS**.
2. From the **CONFIGURE PROCESSORS** screen, select option **(1)**.
3. From the **CONFIGURATION FOR:** menu screen, select option **(4)**.

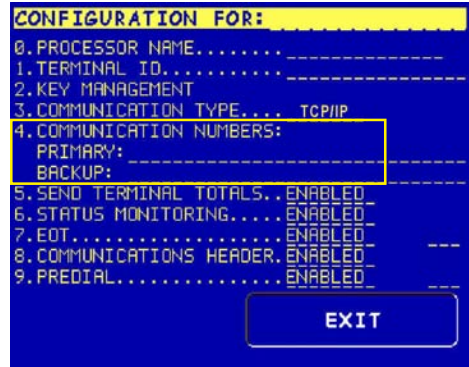

### DESCRIPTION:

The **COMMUNICATION Numbers** function allows entry of the host processors primary and backup (if needed) phone numbers or the **Host TCP/IP Addresses** if running TCP/IP communications type.

The **HOST TCP/IP ADDRESSES** are provided by your host Network Administrator . The first part of the address consists of a sequence of four groups of numbers. Each group can be up to three digits long, and each group is separated by a period (dot character), as in this example: **123.3.01.99** The second part of the address is a **PORT NUMBER**, consisting of five (5) digits or less, separated from the first part by a comma (',' ) character, as in this example: **123.3.01.99,23353**.

Follow these steps to initially enter or change the **PRIMARY HOST TCP/IP ADDRESS**:

- Select which host address you want to enter/change (Primary/Backup).
- Enter the first group of numbers in the IP Address using the main keypad keys.
- Enter a 'dot' character by pressing the <Control> key, then the <0> key **Twice** to select the period', then the <Right Arrow> key to lock it in.
- Repeat Steps 2 and 3 for the second and third group of numbers in the IP Address.
- Enter the fourth group of numbers in the IP Address.
- Enter the comma (",") character by pressing the <Control> key, then the <0> key **Once** to select the comma. Press the <Right Arrow> key to lock it in.
- Enter the **PORT NUMBER**. Select <Enter> to save the Host /IP Address entry, or <Cancel> to discard the changes. Repeat steps for **BACKUP HOST TCP/IP ADDRESS** entry.

**CONFIGURE TERMINAL  
TCP/IP CONFIGURATION**

**ACCESS INSTRUCTIONS:**

1. From the **MAIN MENU** screen, select **CONFIGURE TERMINAL**.
2. From the **CONFIGURE TERMINAL** screen, select **MORE**.
3. From the **MORE** screen, select **COMMUNICATION**.
4. From the **COMMUNICATION** screen, select **TCP/IP CONFIGURATION**.

**DESCRIPTION:**

The **TCP/IP CONFIGURATION** option allows access to setup parameters that control communication between the ATM and the Host Network. It also allows testing of the External Ethernet device.

The following parameters are accessed through this function and described on the following pages:

- ➔ **NETWORK SETTINGS**
- ➔ **TEST TCP/IP**

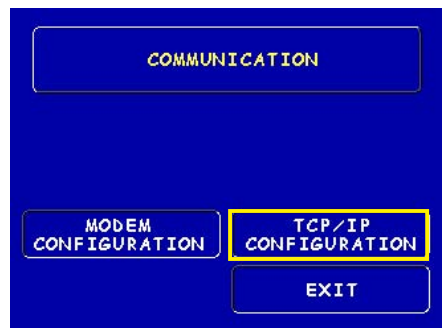
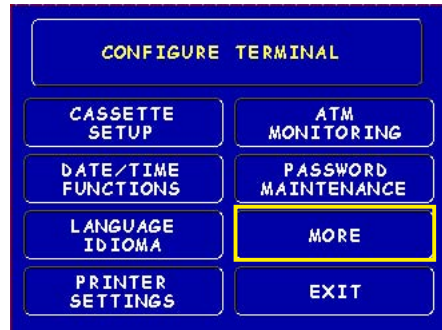

**NETWORK SETTINGS**

**Description:**

The **NETWORK SETTINGS** parameters are provided by your host Network Administrator. The **TERMINAL IP ADDRESS**, **SUBNET MASK**, and **GATEWAY ADDRESS** consist of a sequence of four groups of numbers. Each group can be up to three digits long and each group is separated by a period (dot character), as in this example: **123.3.01.99**

Follow these steps to initially enter or change the **TERMINAL IP ADDRESS**, **SUBNET MASK**, and **GATEWAY ADDRESS**:

- ➔ Select <Change> to blank the current entry, if necessary.
- ➔ Enter the first group of numbers in the Address/Value using the main keypad keys.
- ➔ Enter a 'dot' character by pressing the <Control> key, then the <0> key *Twice* to select the period', then the <Right Arrow> key to lock it in.
- ➔ Repeat Steps 2 and 3 for the second and third group of numbers for the Address/Value.
- ➔ Enter the fourth group of numbers for the Address/Value.
- ➔ Select <Enter> to save the Address/Value entry or <Cancel> to discard the changes.

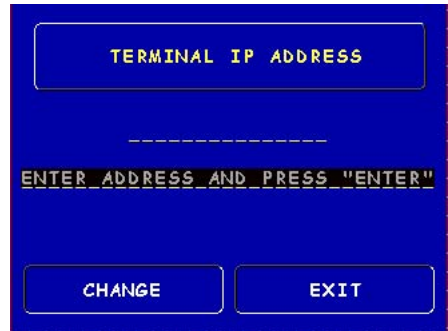
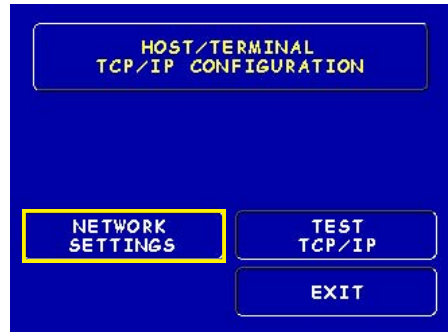

## NETWORK SETTINGS

The **CHIP VERSION** and **MAC ADDRESS** are reference parameters ONLY - no configuring is done. The Chip Version is the software version running on the ATM and the MAC Address is hard-coded from the Ethernet device.

The **TCP/IP TIMEOUT** is defaulted to 120 seconds, but may be increased or decreased depending on response time. Maximum timeout value is 999 seconds.

The **LISTENING PORT** value consists of five (5) digits or less.

Follow the steps below to initially enter or change the **LISTENING PORT**:

- Select <Change> to blank the current entry, if necessary.
- Enter the **LISTENING PORT** number. Select <Enter> to save the Port Entry or <Cancel> to discard the changes.

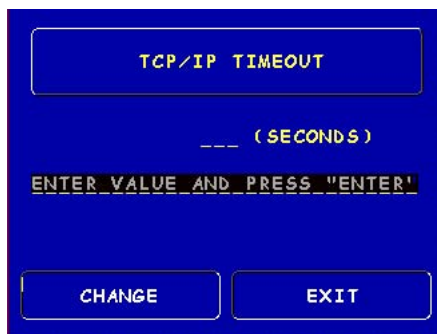

## TEST TCP/IP

### DESCRIPTION:

This option allows testing of the **TCP/IP** device. When selected, the Ethernet PCB assembly initializes and resets the configuration hardware imbedded in the device. If test is successful, a “Tested OK” will be displayed.

### ERROR CONDITION:

If the test fails, an error message will be displayed. Check the cable connections from the External Ethernet device to the Main board. Possible problems could be no or incorrect voltage to unit, IF/Host cable, Main board, or Ethernet PCB assembly.

**Error Code 237 may appear during operation. This code means there is a TCP/IP failure.**

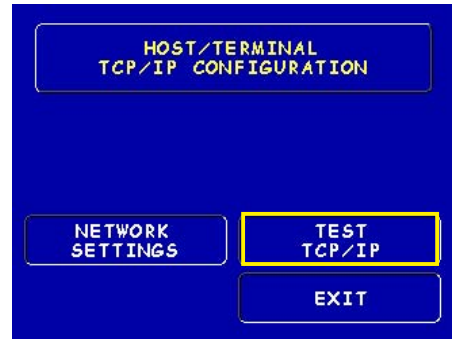

**TRITON CONNECT  
TCP/IP CONFIGURATION**

**ACCESS INSTRUCTIONS:**

1. From the **MAIN MENU** screen, select **CONFIGURE TERMINAL**.
2. From the **CONFIGURE TERMINAL** screen, select **ATM MONITORING**.
3. From the **ATM MONITORING** screen, select **TRITON CONNECT**.
4. From the **TRITON CONNECT** screen, select **TCP/IP CONFIGURATION**.

**\*\* Important \*\***  
If using, turn Triton Connect <ON> after entering the Configuration parameters.

**DESCRIPTION:**

The **TRITON CONNECT** function allows the terminal operator to set up parameters that control **DIAL-UP** and **TCP/IP** communications between the ATM and Triton Connect PC-based software to remotely manage your Triton Systems ATMs. The following **TCP/IP** parameters are accessed through this function and described on the following pages:

- ➔ **Host Numbers**
- ➔ **Alarm Numbers**
- ➔ **TCP/IP Configuration**

**Note: Comms Type Option**  
You must have the External Ethernet device installed. For Model 8100/9100 ATMs, this function detects the communication type installed (Dialup or TCP/IP) and will not allow user to change (toggle).

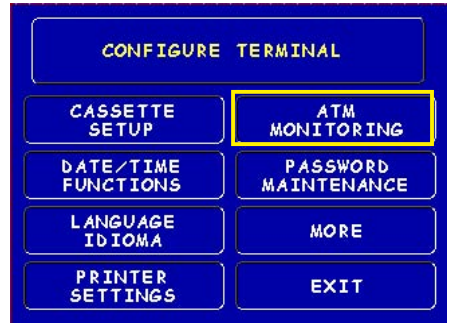

## TRITON CONNECT HOST NUMBERS

### DESCRIPTION:

The **HOST NUMBERS** are provided by your Processor/Host Network administrator. If you are using **TCP/IP** as your communication type, you will need to enter **HOST TCP/IP ADDRESSES**. The first part of the address consists of a sequence of four groups of numbers. Each group can be up to three digits long, and each group is separated by a period (dot character), as in this example: **123.3.01.99** The second part of the address is a **PORT NUMBER**, consisting of four (**4**) digits or less, separated from the first part by a comma (“,”) character, as in this example: **123.3.01.99,9043**.

Follow these steps to initially enter or change the **PRIMARY HOST NUMBER (ADDRESS)**:

- Select <Change> to blank the current entry, if necessary.
- Enter the first group of numbers in the TCP/IP Address using the main keypad keys.
- Enter a ‘dot’ character by pressing the <Control> key, then the <0> key ***Twice*** to select the period’, then the <Right Arrow>key to lock it in.
- Repeat Steps 2 and 3 for the second and third group of numbers in the TCP/IP Address.
- Enter the fourth group of numbers in the TCP/IP Address.
- Enter the comma (“,”) character by pressing the <Control> key, then the <0> key ***Once*** to select the comma. Press the <Right Arrow> key to lock it in.
- Enter the **PORT NUMBER**. Select <Enter> to save the Primary TCP/IP Address entry or <Cancel> to discard the changes. Repeat steps for **BACKUP HOST NUMBER (ADDRESS)** entry.

TRITON CONNECT

HOST NUMBERS

ALARM NUMBERS

COMMS TYPE TCP/IP CALL BACK ON

TCP/IP CONFIGURATION TRITON CONNECT ON

EXIT

TRITON CONNECT  
HOST COMMS NUMBERS

PRIMARY

BACKUP

EXIT

PRIMARY COMMS NUMBER

-----

ENTER NEW NUMBER & PRESS "ENTER"

CHANGE

EXIT



**TRITON CONNECT  
ALARM NUMBERS**

**DESCRIPTION:**

The **ALARM NUMBERS** are provided by your Processor/Host Network Administrator. If you are using **TCP/IP** as your communication type, you will need to enter **ALARM TCP/IP ADDRESSES**. The first part of the address consists of a sequence of four groups of numbers. Each group can be up to three digits long, and each group is separated by a period (dot character), as in this example: **123.3.01.99** The second part of the address is a Port Number, consisting of four (4) digits or less, separated from the first part by a comma (“,”) character, as in this example: **123.3.01.99,9043**.

Follow these steps to initially enter or change the **PRIMARY ALARM NUMBER (ADDRESS)**:

- ➡ Select <Change> to blank the current entry, if necessary.
- ➡ Enter the first group of numbers in the TCP/IP Address using the main keypad keys.
- ➡ Enter a ‘dot’ character by pressing the <Control> key, then the <0> key ***Twice*** to select the period’, then the <Right Arrow> key to lock it in.
- ➡ Repeat Steps 2 and 3 for the second and third group of numbers in the TCP/IP Address.
- ➡ Enter the fourth group of numbers in the TCP/IP Address.
- ➡ Enter the comma (“,”) character by pressing the <Control> key, then the <0> key ***Once*** to select the comma. Press the <Right Arrow> key to lock it in.
- ➡ Enter the **PORT NUMBER**. Select <Enter> to save the Primary Alarm TCP/IP Address entry or <Cancel> to discard the changes. Repeat steps for **BACKUP ALARM NUMBER (ADDRESS)** entry.



**TRITON CONNECT  
TCP/IP CONFIGURATION**

**DESCRIPTION:**

The **TERMINAL IP** and **LISTENING PORT** ADDRESSES are provided by your Host Network Administrator. The Terminal Address consists of a sequence of four groups of numbers. Each group can be up to three digits long, and each group is separated by a period (dot character), as in this example: **123.3.01.99**

The Listening Port value consists of five (5) digits or less. Follow these steps to initially enter or change the **TERMINAL IP ADDRESS** and **LISTENING PORT** values:

- **(TERMINAL IP ADDRESS)** Select <Change> to blank the current entry, if necessary.
- Enter the first group of numbers in the IP Address using the main keypad keys.
- Enter a 'dot' character by pressing the <Control> key, then the <0> key *Twice* to select the period', then the <Right Arrow> key to lock it in.
- Repeat Steps 2 and 3 for the second and third group of numbers in the IP Address.
- Enter the fourth group of numbers in the IP Address. Select <Enter> to save the Terminal IP Address entry or <Cancel> to discard the changes.
- **(LISTENING PORT)** Select <Change> to blank the current entry, if necessary.
- Enter the Listening Port number. Select <Enter> to save the Port Address entry or <Cancel> to discard the changes.

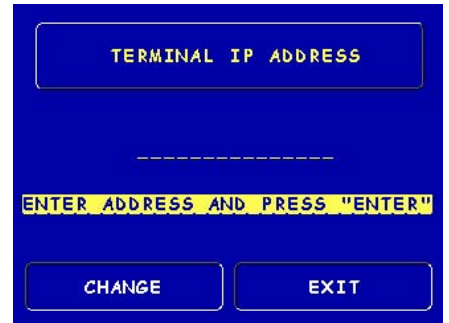

**SECTION 4**  
**CASSETTE CLOSE**  
**CASH REPLENISHMENT**

## INTRODUCTION

The purpose of this section of the manual is to describe the procedures for cassette closing and replenishment. Information concerning note handling and quality issues are explained initially.

## DISPENSING MECHANISMS

The Model 9100 ATM can accommodate most dispensing mechanisms in the TDM family (100/150/200/250). In addition, an SDD and MiniMech (Mech-10) dispenser are also available.

Currency capacity depends upon the dispenser mechanism installed in the ATM, but is also affected by note quality and thickness. Typical capacities are provided in the following table:

9100 DISPENSING MECHANISMS		
DISPENSER	CASSETTE	RECOMMENDED MAXIMUM CAPACITY
TDM-100	Single	650 Notes
TDM-150	Single	1300 Notes
TDM-200	Multiple	650 Notes (per cassette)
TDM-250	Multiple	1300 Notes (per cassette)
MiniMech	Single	750 Notes
SDD	Single	1800 Notes

The dispensing mechanism delivers the appropriate number of notes from the note cassette to fulfill the customer's withdrawal request. The purpose of the reject area or cassette is to accept and hold notes that have been transferred from the note cassette but not dispensed. Some situations that could cause the mechanism to reject notes are: (1) multiple notes stuck together and (2) note width too short or long. Other conditions that could cause a reject are described in the next section, Note Condition.

## NOTE CONDITION

If possible, store currency at room temperature for at least eight hours before dispensing from the cassettes.

The number of rejects can be directly influenced by the technique used to load the cassettes and the quality of the currency. Notes loaded into the cassettes must be in "fit" condition if a high level of performance (low reject and failure rate) is expected from the unit. "Fit" notes do not possess any of the defects listed:

**\*\*WARNING\*\***

**DO NOT RECYCLE REJECTED NOTES INTO A CASSETTE!**  
Doing so could cause more rejects and/or currency jams.

## CURRENCY HANDLING

---

### USED NOTE DEFECTS

- Adhesive or “sticky” substances on the surface of the paper.
- Tears extending more than 1/2” from the edge of the currency.
- Tears, holes, or missing sections in the body of the currency.
- Tape on the surface of the currency used for repairing, patching or any other purpose.
- Staples, pins, or any other foreign body attached to the notes.
- Corner folds of a size greater than 1/2” on either axis.
- Two or more notes joined by any means.
- Excessively crumpled or crinkled.

### NEW OR UNCIRCULATED NOTE DEFECTS

- All the conditions listed for used notes.
- Excessive bowing due to conditions of packing and storing.
- New or uncirculated currency must be “burst” and fully separated prior to loading into cassettes.

### PREPARING NOTES

Use the following procedures to prepare notes before inserting them into a note cassette.

#### PREPARING USED NOTES

- Remove the band around each bundle of notes.
- Remove foreign objects (e.g. pins, paper clips, crumbs, etc.).
- Remove torn or very worn notes.
- Straighten any folded notes.

#### PREPARING NEW OR UNCIRCULATED NOTES

- Remove the band around each bundle of notes. Separate the notes from each other by:
- Striking the bundle hard against the edge of a table or similar object.
- Flipping through each bundle of notes in both directions at each end.
- Using a Note Counter.

## CASSETTE CLOSE

This function is used to complete the balancing of the specified cassette(s). It prints a report summarizing all activity on the selected cassette(s) since the last CASSETTE CLOSE and clears the totals. It also resets the number of bills in the cassette to zero (0).

### \*Note\*

Single feed channel dispensers such as the TDM-1XX only display cassette A, all other cassettes will appear grayed out. The cassette type has a default setting of cash. They are automatically placed in service after boot. The "In-Service" configuration and status items do not apply to single feed channel dispensers.

For the dual feed channel TDM-2XX dispensers, cassettes A through C are available for configuration. Cassette D is not supported for any of the TDM dispensers and should appear grayed out on all management functions screens. The terminal immediately flags non-resident cassettes as out of service once the SW returns from management functions to customer transactions for multi-feed channel mechanisms.

1. Enter **MANAGEMENT FUNCTIONS MAIN MENU** screen.
2. (The screens below represent a single note cassette) Select **CLOSE > CASSETTE CLOSE > SELECT CASSETTE > CASSETTE A: CASSETTE CLOSE**.
3. After selecting Cassette A: Cassette Close, a report will be printed summarizing all activity since the last Cassette Close. The number of bills in the cassette will be reset to zero (0).

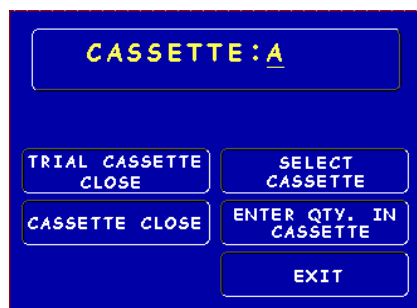
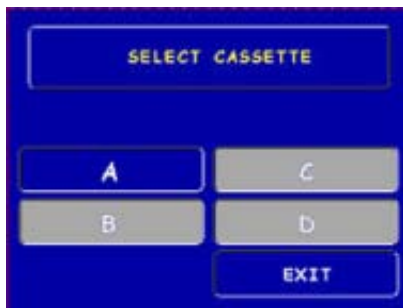
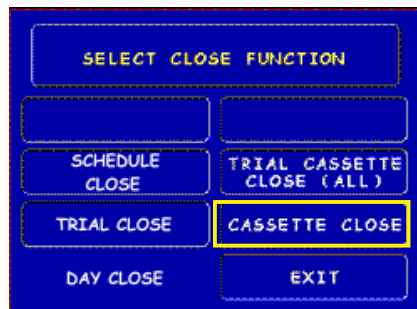

### REPLENISH CASSETTE (TDM-100/150/200/250)

1. Unlock and open the security cabinet door.
2. **(TDM-150/200/250)** Extend the dispenser mounting tray fully as shown below. *Note: The TDM-100 uses a fixed-tray mounting system.*
3. To gain access to the cassette(s), rotate the mechanism mounting platform to the “Service” position:
  - Locate the spring-loaded locking pin on the underside of the tray.
  - Pull the pin down to release the swivel mounting platform.
  - Slowly turn the tray **clockwise 180°** so that the note and reject cassette(s) can be accessed from the front of the unit.
  - Release the locking pin and move the mounting platform back and forth slightly to ensure the pin snaps back into place, locking the mounting platform into the service position.



*Lift up on slide tray locking levers.*



*Rotate mechanism to “Service” position (clockwise).*

4. To remove the note cassette(s), grasp the cassette handle and pull in a firm but controlled manner to release the cassette from the snap catches. Try to use only the minimum amount of force to release the cassette! The cassette will only move a few inches! Once released from the snaps, you can slide the cassette out of the mechanism. Place the cassette on a level, flat surface for replenishment.



*Removing note cassette (TDM-100).*

### LOADING THE CURRENCY CASSETTE

1. Unlock and open the cassette lid using the supplied key. Move the pusher plate to the rear of the cassette (toward the handle).

**Note:** The cassette(s) use a locking mechanism to hold the packer plate in the loading position. Pull the pusher-plate all the way back to the handle end of the cassette and turn the key to latch the pusher plate into the loading position.



*Unlock and open note cassette.*



*Pull the packer plate back. Allow the pusher-plate to be latched in position using the key-lock.*

2. Count the number of bills that remain in the cassette, if any. Next, count the number of bills that are being added into the cassette.
3. Add the number of bills being placed into the cassette to the number that remained. The **“Total”** number of these bills will be entered in the **“ENTER QTY. IN CASSETTE”** option. Place the currency into the cassette between the pusher plate and front of cassette.
4. Turn the key to release the catch, allowing the pusher plate to compress the notes. Hold notes while allowing plate to move.
5. Close and lock the cassette. Remove the key. Slide the cassette back into its compartment in the dispensing mechanism. Make sure the cassette is fully inserted! You will feel the cassette latch securely into the snap catches.

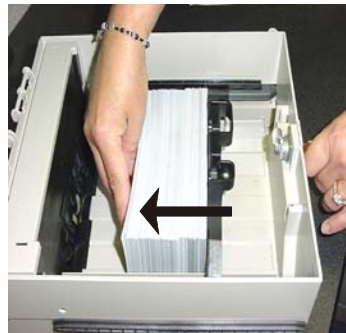



### REMOVING THE REJECT CASSETTE

The reject tray is located just above the currency cassette(s) in the dispensing mechanism. Follow these steps to remove the reject tray:

1. Slide the reject tray out of its compartment in the dispensing mechanism. Place the tray on a flat surface.
2. Unlock the tray using the supplied key. Flip the top back to gain access to the reject compartment.



*Remove reject cassette.*



*Unlock and open reject cassette.*

3. Remove any notes in the reject compartment. Close and lock the reject tray. Remove the key. Slide the cassette back into its compartment in the dispensing mechanism. Make sure the reject cassette is fully inserted! You will feel the cassette snap securely into the catches.

**Note:** You may wish to record the denomination and number of notes removed from the reject tray for use when balancing the note tray against the cassette/day close records.

**\*\*WARNING\*\***

**DO NOT RECYCLE REJECTED NOTES INTO A CASSETTE!**

Doing so could cause more rejects and/or currency jams.

## ROTATE DISPENSER MECHANISM

1. After reinstalling the currency and reject cassettes, pull down on the swivel platform locking pin to allow the swivel platform to turn.
2. Rotate the mechanism *counterclockwise 180°* back to the “Operate” position. (TDM-150/200/250)  
- Push the mounting tray back into the security cabinet



*Rotate mechanism to operate position (counterclockwise).*



*Mechanism in “Operate” position.*

3. Select **ENTER QTY. IN CASSETTE** option. This option allows entry of the number of notes in the cassette. This number is used as the starting point for the cassette close report. **\*Note: Enter the total number of notes in the cassette, NOT the value of the documents.**

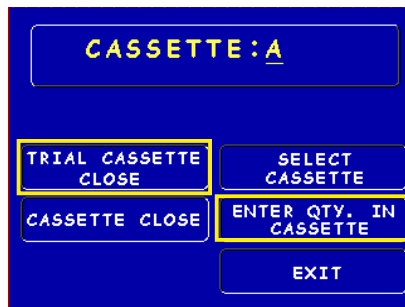

4. Select **TRIAL CASSETTE CLOSE** option. A report will be printed verifying the amount of bills you entered in the previous step. Totals are **not cleared** or reported to the host.
5. Close/lock the security door.

### REPLENISH CASSETTE (SDD)

1. Unlock and open the security cabinet door.
2. To remove the cassette, grasp the handle on the front of the dispensing mechanism with one hand while holding the mechanism in place with the other hand and pull sharply. ***Do not allow the cassette to swing freely when it is pulled out. It may strike a near by object or person causing damage to or injury to what it strikes!***
3. The cassette must be primed with the cassette key before it can be inserted onto the loading tray. Insert the cassette key (barrel-shaped) and turn clockwise to show the “Green” indicator in the window on the side of the cassette.

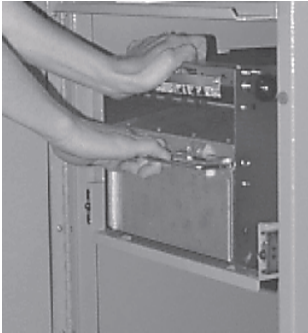

*Remove cassette.*

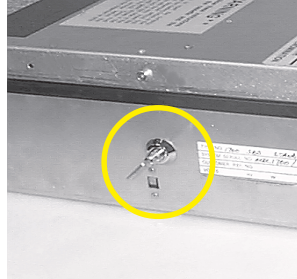

*Insert key.*



Cassette  
“unprimed”

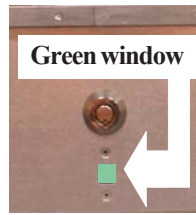

Cassette  
“primed”

**\*\*\*WARNING\*\*\***

**If RED is indicated in the window on the side of the currency cassette, NEVER attempt to insert the cassette into the dispenser or the loading tray!**

- Place the cassette onto the loading tray provided with the back of the cassette facing the probes on the tray. The shutter is unlocked as the cassette is pushed into the probes.



*Loading Tray.*

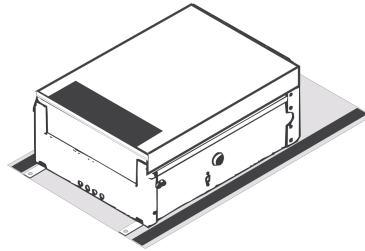

*Cassette on Loading Tray.*

- Lift the cassette lid to expose the reject tray. Remove any rejected notes. Lift the reject tray to gain access to the currency compartment.

**Note:** You may wish to record the number of notes removed from the reject tray for use when balancing the note tray against the cassette/day close records.

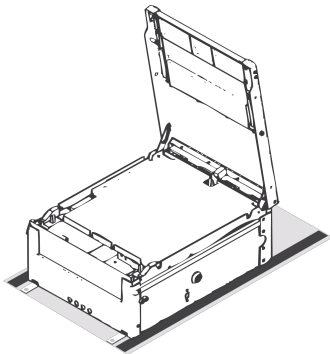

*Cassette opened.*

**\*\*WARNING\*\***

**DO NOT RECYCLE REJECTED NOTES INTO A CASSETTE!** Doing so could cause more rejects and/or currency jams.

- Pull the packer plate to the rear of the cassette (away from the shutter) until it locks to the white packer plate latch. It will be necessary to push down on the packer plate latch to lock the packer plate in place. The packer plate will be held in this position until the lid is closed or the latch is released by pushing it down. Be careful not to release the packer plate onto your fingers.

## CURRENCY HANDLING

---

7. Count the number of bills that remain in the cassette, if any. Next, count the number of bills that are being added into the cassette.
8. Add the number of bills being placed into the cassette to the number that remained. The “**Total**” number of these bills will be entered in the “**ENTER QTY. IN CASSETTE**” option.
9. Place the currency into the cassette. Allow at least one inch of clearance between the packer plate when it is fully retracted and the currency. This will allow the packer plate to compress the currency.
10. Release the packer plate and lower the reject tray and the lid. The cassette can now be removed from the loading tray by sliding it away from the probes.
11. **VERIFY THAT THE CASSETTE IS PRIMED!** Be certain the “**Green**” indicator is showing in the window below the key! Install the cassette into the dispenser by placing the cassette guides on the dispensers’ rails and firmly pushing the cassette in until it locks in place.
12. Close and lock the security container.

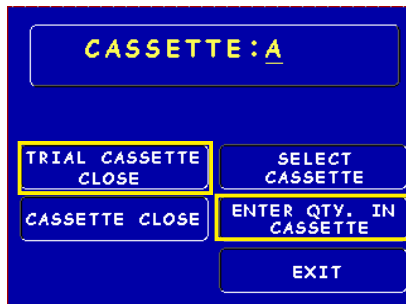

13. Select **ENTER QTY. IN CASSETTE** option. This option allows entry of the number of notes in the cassette. This number is used as the starting point for the cassette close report. *\*Note: Enter the total number of notes in the cassette, NOT the value of the documents.*
14. Select **TRIAL CASSETTE CLOSE** option. A report will be printed verifying the amount of bills you entered in the previous step. Totals are **not cleared** or reported to the host.

### REPLENISH CASSETTE MECH 10 (MINIMECH)

1. Unlock and open the security cabinet door.
2. To remove the note tray, grasp the tray handle and slide the tray out of the mechanism. Place note tray on a flat level surface.
3. Remove any rejected notes. The reject compartment is located nearest the handle side of the tray.

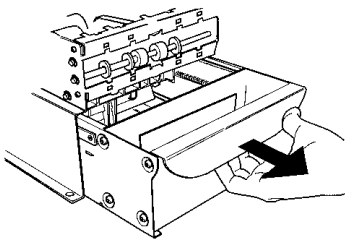

*Removing note tray from the dispensing mechanism.*

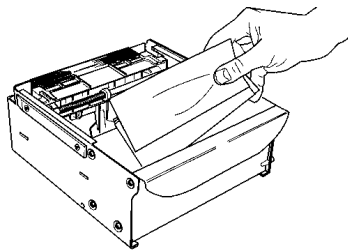

*Removing rejected notes.*

**Note:** You may wish to record the number of notes removed from the reject compartment for use when balancing the note tray against the cassette/day close records.

#### **\*\*WARNING\*\***

**DO NOT RECYCLE REJECTED NOTES INTO A CASSETTE!**  
Doing so could cause more rejects and/or currency jams.

### LOADING THE NOTE TRAY

1. Move the pusher plate to the rear of the tray (toward the handle). Ensure the pusher plate is fully back. Maintain pressure on the pusher plate as needed while loading notes.
2. Count the number of bills that remain in the cassette, if any. Next, count the number of bills that are being added into the cassette.
3. Add the number of bills being placed into the cassette to the number that remained. The “**Total**” number of these bills will be entered in the “**ENTER QTY. IN CASSETTE**” option.
4. Place the currency into the cassette. Allow at least one inch of clearance between the packer plate when it is fully retracted and the currency. This will allow the packer plate to compress the currency.

## CURRENCY HANDLING

5. Make sure the note pile is as even as possible. If necessary, use your hands to smooth and level the pile.

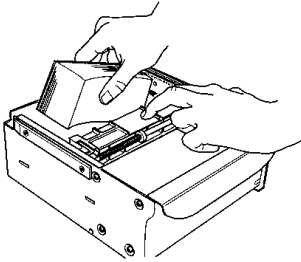

*Load note tray with currency.*

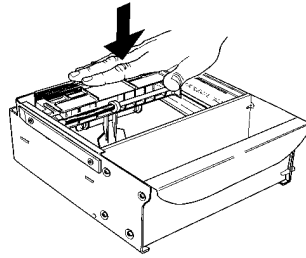

*Level the note pile.*

6. Release the pusher plate against the notes.
7. Using the handle, slide the note tray into the dispensing mechanism. Make sure the note tray is fully inserted!

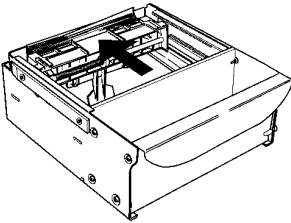

*Release packer plate.*

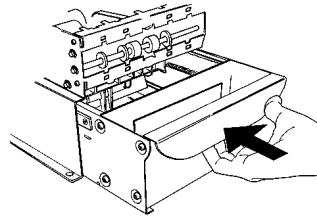

*Slide note tray into dispenser mechanism.*

8. Close and lock the security container.
9. Select **ENTER QTY. IN CASSETTE** option. This option allows entry of the number of notes in the cassette. This number is used as the starting point for the cassette close report. **\*Note: Enter the total number of notes in the cassette, NOT the value of the documents.**
10. Select **TRIAL CASSETTE CLOSE** option. A report will be printed verifying the amount of bills you entered in the previous step. Totals are **not cleared** or reported to the host.

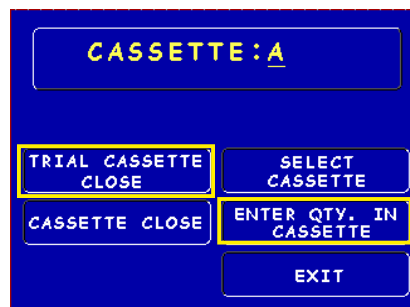

**THIS PAGE INTENTIONALLY LEFT BLANK**



**SECTION 5**  
**GENERAL MAINTENANCE**

## INTRODUCTION

This section of the manual covers preventive and corrective maintenance procedures appropriate for user personnel. The following areas are covered:

1. **REPLENISHING RECEIPT PAPER.** Describes how to replace a spent receipt paper roll.
2. **CLEANING THE ENCLOSURE.** The proper way to clean the ATM housing.
3. **CARD READER CLEANING.** The recommended card reader cleaning technique.

### **\*Important\***

Should a malfunction occur, **DO NOT** attempt to service the unit yourself! Only qualified service personnel are authorized to repair or service the terminal. Contact your Triton certified service provider!

## REPLENISHING THE RECEIPT PAPER

*NOTE: This operation must be completed with the AC power applied to the ATM.*

1. Open the top of the ATM by unlocking the top enclosure and pulling the hinged door forward.
2. If paper remains on the roll, cut or tear the paper between the roll and the printer (Figure 5-1).

### **\*\* Caution \*\***

**DO NOT** pull receipt paper backwards through the printer! This may leave paper fragments that can cause paper jams.

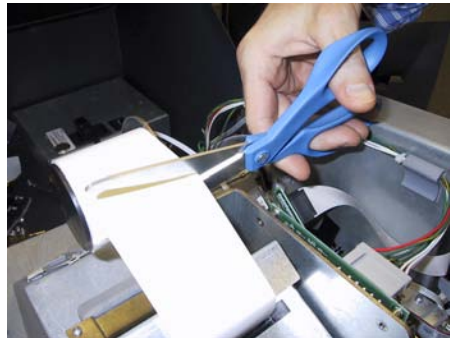

*Figure 5-1. Cut paper between the roll and the printer feed path.*

3. Use the receipt printer feed button (as shown in Figure 5-2) to feed the paper through the paper path until all paper comes out the front of the printer.
4. Remove the paper and spool from the paper bracket (Figure 5-3).

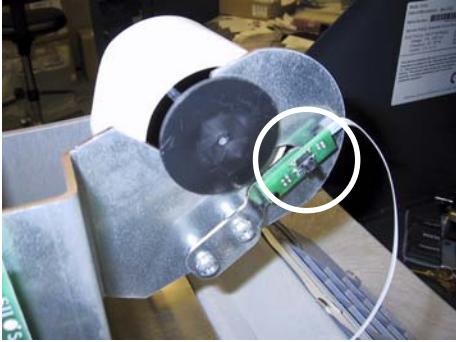

Figure 5-2. Paper feed button location.



Figure 5-3. Remove paper roll from bracket.

5. Remove the tab securing the end of the new paper roll to itself. Use scissors to cut off all of the paper up to and including the glue tab.

Remove the plastic spindle from the old paper roll and insert the spindle into the new roll of paper. Use a 4-inch roll of 60 mm wide thermal paper.

Be sure the spindle is inserted so that the paper will feed from the top of the roll when it is installed on the paper bracket.

6. Place the new roll back on the paper bracket by sliding the small, slotted end of the spindle onto the slot in the bracket as shown in Figure 5-4. **Note that the paper feeds from the TOP of the roll!**



Figure 5-4. Place paper roll on bracket.  
Paper feeds from top of roll!

7. Feed the end of the paper into the printer take-up slot (Figure 5-5). The printer will activate and automatically feed the paper through the printer and slightly out the front of the control panel.
8. If the printer does not feed automatically, open the printer assembly by loosening the thumbscrew on the side as shown in Figure 5-6.



Figure 5-5. Feed paper into the printer take-up slot.

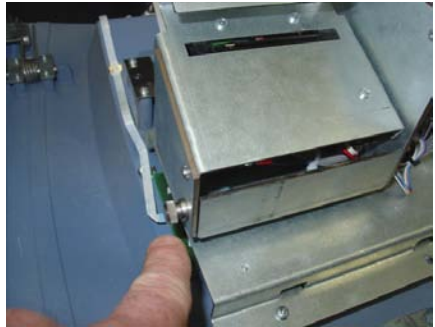

Figure 5-6. Thumbscrew location.

9. Rotate the printer towards the front of the unit (Figure 5-7).
10. Check the blue lever to ensure it's in the correct position as shown in Figure 5-8. If it is not in the position shown, move the lever (moves in 3 positions) to the correct position. Close the printer assembly and perform step 7 again.

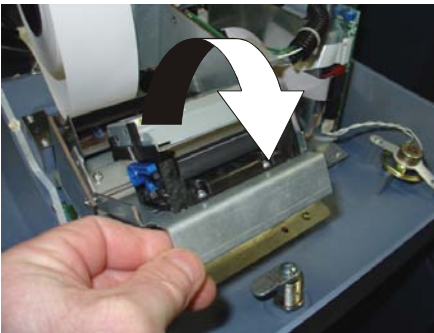

Figure 5-7. Rotate printer open.

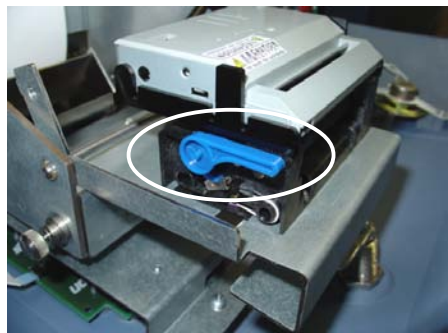

Figure 5-8. Blue tension lever (correct position).

11. Close and lock the control panel. Go to **MANAGEMENT FUNCTIONS > DIAGNOSTICS** and perform a **TEST RECEIPT PRINTER**. If the test receipt is printed successfully, place the ATM back in service.

## GENERAL MAINTENANCE

---

### CLEANING THE ENCLOSURE

The ATM front panel is highly durable, resisting scratches and finger smudges. However, occasional cleaning of the front panel and the plastic enclosure may be desirable. A soft dry or slightly damp cloth may be used for cleaning. For best results, use a weak solution of a mild detergent and water.

**\*\* Caution \*\***

**Avoid using abrasive cleaners on any surface of the terminal.  
Do not spray liquid cleaner directly on the unit.**

### CLEANING THE DISPLAY

The Liquid Crystal Display (LCD) on the front of the ATM has a plastic protective window that should be cleaned only with a soft cloth, dampened with a weak solution of a mild detergent and water.

**\*\* Caution \*\***

**Do not use any abrasive cleaners on the window as it will scratch.  
Do not spray liquids onto the screen as they may run down inside  
the unit and cause damage.**

### CARD READER CLEANING

Special cleaning cards (P/N 06200-00055) are available for proper maintenance of the card reader. The reader should be cleaned at least once a month by inserting and removing a cleaning card, as shown below. It may be necessary to clean the card reader more often in locations that see heavy usage.

1. Remove the cleaning card from the sealed pouch.
2. Insert the cleaning card into the card reader and move in and out several times.
3. Remove the cleaning card and turn over to use other side.
4. Insert again several times.
5. Remove cleaning card and discard.



**THIS PAGE INTENTIONALLY LEFT BLANK**

**SECTION 6**  
**ERROR CODES**  
**TDM CLICK COUNTS**

<b>ERROR CODES</b>	
<b>Error Code</b>	<b>Meaning</b>
<b>32</b>	<b>Good operation</b>
<b>33</b>	<b>Feed failure (Mech-10, SDD)</b>
<b>34</b>	<b>Mis-tracked note at feed (Mech-10, SDD)</b>
<b>35</b>	<b>Mis-tracked note at double detect (Mech-10, SDD)</b>
<b>36</b>	<b>Mis-tracked note at exit (Mech-10, SDD)</b>
<b>37</b>	<b>Too long at exit (Mech-10, SDD)</b>
<b>38</b>	<b>Blocked exit (Mech-10, SDD)</b>
<b>39</b>	<b>Too many notes (Mech-10, SDD)</b>
<b>42</b>	<b>Transport error (Mech-10, SDD)</b>
<b>44</b>	<b>Bad roller profile (Mech-10, SDD)</b>
<b>45</b>	<b>Diverter error (Mech-10, SDD)</b>
<b>46</b>	<b>Exit quantified (Mech-10, SDD)</b>
<b>47</b>	<b>Note missing at double detect (Mech-10, SDD)</b>
<b>48</b>	<b>Reject rate exceeded</b>
<b>49</b>	<b>Jam at exit (Mech-10, SDD)</b>
<b>50</b>	<b>Interference recovery (Mech-10, SDD)</b>
<b>51</b>	<b>Suspect exit accountancy</b>
<b>52</b>	<b>Ram error (Mech-10, SDD)</b>
<b>53</b>	<b>EPROM error (Mech-10, SDD)</b>
<b>54</b>	<b>Operation timeout (Mech-10, SDD)</b>
<b>55</b>	<b>RAM corruption (Mech-10, SDD)</b>
<b>56</b>	<b>Link error (Mech-10, SDD)</b>
<b>76</b>	<b>Communications error with Electronic Journal (EJ)</b>
<b>89</b>	<b>Unexpected note in extension (TDM-Billfish)</b>
<b>96</b>	<b>Billfish cable error (TDM)</b>



**ERROR CODES / TDM CLICK COUNTS**

<b>ERROR CODES</b>	
<b>Error Code</b>	<b>Meaning</b>
<b>97</b>	<b>Trailing edge timeout at Billfish exit (TDM)</b>
<b>98</b>	<b>Billfish exit timeout (TDM)</b>
<b>99</b>	<b>Excessive skew detected (Billfish-TDM)</b>
<b>100</b>	<b>Trailing edge timeout at skew 5(Billfish-TDM)</b>
<b>101</b>	<b>Error (2 sec. timeout waiting for pick) - feed failure (TDM)</b>
<b>102</b>	<b>Dispenser - timeout at exit sensor</b>
<b>103</b>	<b>Thickness sensor unstable</b>
<b>104</b>	<b>Unable to clear width sensors during reject</b>
<b>105</b>	<b>Insufficient notes to learn</b>
<b>106</b>	<b>FIFO (First In First Out) error</b>
<b>107</b>	<b>Suspect reject accountancy</b>
<b>108</b>	<b>Unexpected note at thickness sensor</b>
<b>109</b>	<b>Timeout at exit sensor</b>
<b>110</b>	<b>Trailing edge timeout at exit</b>
<b>111</b>	<b>Diverter timeout</b>
<b>112</b>	<b>Timeout waiting for leading edge at reject</b>
<b>113</b>	<b>Timeout waiting for trailing edge at reject</b>
<b>114</b>	<b>Exit blocked during purge</b>
<b>115</b>	<b>Diverter timeout on purge</b>
<b>116</b>	<b>Motor fault</b>
<b>117</b>	<b>Timeout waiting for notes to divert</b>
<b>118</b>	<b>Exit sensor blocked on start of dispense or learn</b>
<b>119</b>	<b>Diverter in dispense position on start of dispense or learn</b>
<b>120</b>	<b>Reject cassette not present</b>
<b>121</b>	<b>Note cassette not present</b>

<b>ERROR CODES</b>	
<b>Error Code</b>	<b>Meaning</b>
122	Unexpected note at exit
123	Hardware error (see Hardware Status Codes table)
124	Diverter moved to exit position during reject/purge
125	Initial status check failed
126	Diverter moved to reject position during dispense
127	Jam in Billfish
128	Error in reply from dispenser
129	Dispenser not responding
130	No acknowledge from dispenser
131	No CTS (Ready) from dispenser
132	Status reported bad double detect in previous dispense
133	5 volts not present from dispenser
134	Status reported exit blocked
135	Status reported feed sensor blocked
136	Modem initialization failed
138	Print failure to receipt
139	Printer controller not responding
140	Timeout waiting for printer to be ready
141	Status reported paper jam
142	Dispenser returns bad command error
144	No reply from the EJ
145	Error in reply from the EJ
146	No reply from command to EJ
147	Error in reply from EJ
148	Write to EJ failed

**ERROR CODES / TDM CLICK COUNTS**

<b>ERROR CODES</b>	
<b>Error Code</b>	<b>Meaning</b>
<b>149</b>	<b>Read from EJ failed</b>
<b>150</b>	<b>Status command to EJ failed</b>
<b>151</b>	<b>EJ full</b>
<b>152</b>	<b>EJ corrupt</b>
<b>153</b>	<b>EJ download failed</b>
<b>154</b>	<b>Unknown EJ status</b>
<b>155</b>	<b>EJ modify record failed</b>
<b>156</b>	<b>Cassette(s) not in service</b>
<b>157</b>	<b>Erase command to EJ failed</b>
<b>158</b>	<b>Format command to EJ failed</b>
<b>159</b>	<b>EJ test feature failed (Feature 00)</b>
<b>160</b>	<b>EJ set feature failed</b>
<b>161</b>	<b>EJ clear feature failed</b>
<b>162</b>	<b>EJ get serial number failed</b>
<b>163</b>	<b>Terminal did not answer Triton Connect (TC). TC error</b>
<b>164</b>	<b>Terminal did not return call to Triton Connect. TC error</b>
<b>165</b>	<b>EJ not present</b>
<b>166</b>	<b>Bad dispense</b>
<b>167</b>	<b>Reported low cash to Triton Connect</b>
<b>168</b>	<b>Software download to terminal failed. TC error</b>
<b>182</b>	<b>Currency cassette low (SDD)</b>
<b>183</b>	<b>Receipt printer paper low</b>
<b>185</b>	<b>Telephone number not configured</b>
<b>186</b>	<b>Bill size not configured</b>
<b>187</b>	<b>Maximum withdrawal not configured</b>
<b>188</b>	<b>PIN working key not configured</b>

<b>ERROR CODES</b>	
<b>Error Code</b>	<b>Meaning</b>
189	Terminal ID not configured
190	PIN Master key not configured
192	Communication error
195	Receipt printer out of paper
196	Card reader error
203	SPED/VEPP keypad not responding to main board
205	SPED/VEPP keypad reported a tamper condition
206	SPED/VEPP could not perform a successful command
207	SPED/VEPP not detected
210	Dispenser type unknown
236	Failed to make connection to TCP/IP host
237	TCP/IP device failed or no TCP/IP device
238	Dispenser compromise - dispenser turned off in the middle of a dispense command to try and get a note ejected on next dispenser reset
239	SPED/VEPP serial number changed
240	SPED/VEPP self test error
241	SPED/VEPP warning - self test error, low battery
246	Change default password(s)
343	Sensor error or sensor uncovered
382	Dispenser cassettes disabled (All)

## ERROR CODES / TDM CLICK COUNTS

<b>COMMUNICATION ERROR CODES</b>	
<b>Error Code</b>	<b>Meaning</b>
1	Timeout
3	Back Ground Dial (BGD) - no answer
4	Error in modem data
5	Connect 1200 baud, lost carrier/connection
6	BGD - no dial tone
7	BGD - busy
10	BGD - logon
11	No connect
13	BGD - done good
14	BGD - done bad
15	Timeout waiting for End of Transmission (EOT)
16	Communications problem
17	No EOT
18	Overflow
48	No answer
65	Processor not communicating with modem correctly
108	No response - request was sent but no response received after a specified time (60 sec)
109	No ENQ - negotiation to the host was complete, but no ENQ was received (dial-up protocol only)
110	Invalid response - request was sent but invalid data was received while waiting for the beginning of a response
112	Invalid LRC (Logitudinal Redundancy Check) - the LRC received in the response was not valid
113	Response format error - a response was received, the LRC was validated, but an error in the response format was found
<p><b>Note:</b> The status codes listed above do not normally cause the terminal to enter an "Out of Service" condition or to display an On-screen status code.</p> <p>Refer to the terminals "Electronic Journal" data for indications of these conditions.</p>	

**CLICK COUNTER HARDWARE STATUS CODES**

The TDM-series click counter has new hardware status codes. The terminal will display and log Error Code **123**. It will then log the actual error in the click count. If there is a '116' in the click count, there will be a number immediately following that describes the error cause.

*Ex: In the click history, you see '116', followed by '18'. This indicates a hardware error caused by the Extension Door Open.*

<b>Description</b>	<b>Status Code</b>
Double detect (0) not connected	1
Width sensor (0) not connected (Tx)	2
Width sensor (0) not connected (Rx)	3
Double detect (1) not connected	4
Width sensor (1) not connected (Tx)	5
Width sensor (1) not connected (Rx)	6
Double detect (2) not connected	7
Width sensor (2) not connected (Tx)	8
Width sensor (2) not connected (Rx)	9
Double detect (3) not connected	0
Width sensor (3) not connected (Tx)	11
Width sensor (3) not connected (Rx)	12
Diverter sensor not connected	13
Timing wheel sensor not connected	14
Exit sensor not connected	15
Reject sensor not connected	16
Extension sensor not connected	17
Extension door open	18
Extension main cable disconnected	19
12-volt supply low	20
12-volt supply high	21
24-volt supply low	22
24-volt supply high	23
Missing pick motor feedback	24
Missing solenoid feedback	25
Pick motor fuse blown	26
Transport motor fuse blown	27

TDM CLICK COUNTERS

<b>Click Count</b>	<b>Description</b>
1	Non maskable interrupt - Terminal power shutdowns
2	Stack overflow
3	Stack underflow
4	Trap illbus
5	Trap illina
6	Trap illopa
7	Class B trap
8	Trap prtflt
9	Trap undopc
10	Trap unknown trap
11	CTS timeout
12	Tx Ack error
13	Tx Nak error
14	Tx EOT error
15	Tx response error - Main board
16	LRC error
17	Framing error
18	Overrun error
19	Parity error
20	Verify error - Main board
21	Process error
22	NVRAM read error
23	NVRAM write error
24	Reject rate exceeded - More than 9 notes rejected during a dispense
25	Unexpected note at thickness 0
26	Buffer overflow error
27	Host reset - Mechanism resets
28	Unexpected note at exit during a dispense
29	Width sensors detected note thinner than double-detect
30	Width sensors detected note thicker than double-detect
31	Width sensors disapproved note double-detect

**TDM CLICK COUNTERS**

<b>Click Count</b>	<b>Description</b>
32	Width sensors thickness reading
33	Undefined
34	Pick motor timeout - Cassette "A"
35	Pick motor overcurrent - Cassette "A"
36	Thickness sensor unstable - Cassette "A"
37	Skew timeout - Cassette "A"
38	Thickness sensor timeout - Cassette "A"
39	Number of resets - Terminal power-up
40	Exit sensor timeout
41	Exit sensor trailing edge timeout
42	Diverter timeout
43	Reject sensor leading edge timeout
44	Reject sensor trailing edge timeout
45	Exit blocked during purge
46	Diverter timeout on purge
47	Width sensor blocked on start of dispense or learn
48	Exit sensor blocked on start of dispense or learn
49	Diverter in dispense position on start of dispense or learn
50	Reject cassette not present
51	Note cassette not present
52	Unexpected note at exit sensor
53	Unexpected note at width sensor
54	Diverter moved to exit position during reject or purge - Dispenser fault
55	Initial status check failed
56	Diverter moved to reject position during dispense - Dispenser fault
57	Unexpected note at reject sensor
58	Excessive skew on leading edge - Cassette "A"
59	Excessive skew on trailing edge - Cassette "A"
60	Note too wide - Cassette "A"
61	Note too narrow - Cassette "A"
62	Note too thick - Cassette "A"



TDM CLICK COUNTERS

Click Count	Description
63	Note too thin
64	Solenoid overcurrent
65	Timeout waiting for diverter - Diverter fault
66	Trailing edge timeout at width sensor - Cassette "A"
67	Watch dog reset
68	UART loop back failed
69	CRC flash check failed
70	CRC NVRAM check failed
71	Note not linear at trailing edge
72	Trailing edge timeout at thickness sensor
73	Oscillator WD
74	Forced reject - Will reject 2 notes (1 bad,1 good)
75	Timeout waiting for unexpected note to clear
76	Error in exit accountancy
77	Error in reject accountancy
78	A2D alignment error
79	Unable to clear width sensor during reject - After 9 attempts
80	Retried dispense operation
81	Retry event count
82	A2D Ch15A comparator reference (2.5V)
83	A2D Ch.14A 24VDC (reading x 6)
84	A2D Ch.13 12VDC (reading x 3)
85	A2D Ch.12 Not used
86	A2D Ch.11 Low currency A (not connected)
87	A2D Ch.10 Exit sensor voltage
88	A2D Ch.9 Reject sensor voltage
89	A2D Ch.8 Width sensor 2 voltage A
90	A2D Ch.7 Width sensor 1 voltage A
91	A2D Ch.6 Width sensor 0 voltage A
92	A2D Ch.5
93	A2D Ch.4

**TDM CLICK COUNTERS**

<b>Click Count</b>	<b>Description</b>
94	A2D Ch.3
95	A2D Ch.2 Double detect voltage A
96	A2D Ch.1 Not used
97	A2D Ch.0 Billfish feedback
98	Logic sensors diverter/dispenser position
99	A2D Ch.11 B Low currency B
100	A2D Ch.8 B Width sensor 2 voltage B
101	A2D Ch.7 B Width sensor 1 voltage B
102	A2D Ch.6 B Width sensor 0 voltage B
103	A2D Ch.2 B Double detect B
104	A2D Ch.11 C Low currency C
105	A2D Ch.8 C Width sensor 2 voltage C
106	A2D Ch.7 C Width sensor 1 voltage C
107	A2D Ch.6 C Width sensor 0 voltage C
108	A2D Ch.2 C Double detect C
109	A2D Ch.11 D Low currency D
110	A2D Ch.8 D Width sensor 2 voltage D
111	A2D Ch.7 D Width sensor 1 voltage D
112	A2D Ch.6 D Width sensor 0 voltage D
113	A2D Ch.2 D Double detect D
114	Jam in Billfish
115	Motor fault - Main transport
116	Bad connection - Billfish door open, connectors, voltage
117	Cassettes shuffled - Cassette(s) not "In Service"
118	Trailing edge timeout at Billfish entrance
119	Billfish exit timeout
120	Billfish excessive skew
121	Trailing edge timeout at Billfish exit - Idler rollers "popped" out
122	Excessive skew on leading edge 1 - Note loading issue
123	Excessive skew on leading edge 2
124	Excessive skew on leading edge 3

TDM CLICK COUNTERS

<b>Click Count</b>	<b>Description</b>
125	Excessive skew on trailing edge 1
126	Excessive skew on trailing edge 2
127	Excessive skew on trailing edge 3
128	Note too wide 1
129	Note too wide 2
130	Note too wide 3
131	Note too narrow 1
132	Note too narrow 2
133	Note too narrow 3
134	Note too thick 1 - Cassette "B" (picked 2 notes)
135	Note too thick 2
136	Note too thick 3
137	Note too thin 1
138	Note too thin 2
139	Note too thin 3
140	Trailing edge timeout at thickness sensor 1
141	Trailing edge timeout at thickness sensor 2
142	Trailing edge timeout at thickness sensor 3
143	Trailing edge timeout at width sensor 1 - 2 notes picked
144	Trailing edge timeout at width sensor 2
145	Trailing edge timeout at width sensor 3
146	Pick motor timeout 1 - Cassette "B"
147	Pick motor timeout2
148	Pick motor timeout 3
149	Pick motor overcurrent 1
150	Pick motor overcurrent 2
151	Pick motor overcurrent 3
152	Skew timeout 1 - Note skewed (width sensor)
153	Skew timeout 2
154	Skew timeout 3
155	Thickness sensor timeout 1 - Double detect fault

TDM CLICK COUNTERS

Click Count	Description
156	Thickness sensor timeout 2
157	Thickness sensor timeout 3
158	Width sensor blocked on start of dispense or learn 1
159	Width sensor blocked on start of dispense or learn 2
160	Width sensor blocked on start of dispense or learn 3
161	Note cassette not present 1
162	Note cassette not present 2
163	Note cassette not present 3
164	Unexpected note at width sensor 1 - Cassette "B" (check cassette)
165	Unexpected note at width sensor 2
166	Unexpected note at width sensor 3
167	Note not linear at trailing edge 1
168	Note not linear at trailing edge 2
169	Note not linear at trailing edge 3
170	Timeout waiting for unexpected note to clear 1
171	Timeout waiting for unexpected note to clear 2
172	Timeout waiting for unexpected note to clear 3
173	Unable to clear width sensor during reject 1 - Cassette "B" (note jam)
174	Unable to clear width sensor during reject 2
175	Unable to clear width sensor during reject 3
176	Unexpected note at thickness 1 - Cassette "B"
177	Unexpected note at thickness 2
178	Unexpected note at thickness 3
179	Leading edge timeout at channel interface
180	Trailing edge timeout at channel interface
181	Excessive skew at channel interface
182	Timeout waiting for FIFO
183	Unexpected note in extension - enable "Extension Reject" option (RT)
184	Billfish motor fault - Timing wheel, jammed notes
185	Operation timeout
186	Billfish cable error - Feedback error (electronic loop)

lower/top feed ch.

TDM CLICK COUNTERS

<b>Click Count</b>	<b>Description</b>
187	Learn error
188	FIFO error
189	Timeout waiting for notes to divert
190	Unable to open process
191	Billfish entrance volt A
192	Billfish entrance volt B
193	Billfish exit volt A
194	Billfish exit volt B
195	Skew board volt A
196	Skew board volt B

**THIS PAGE INTENTIONALLY LEFT BLANK**

**APPENDIX A**  
**WARRANTY AND REPAIR**  
**POLICIES/PROCEDURES**

**WARRANTY STATEMENT**

Manufacturer warrants that the Products delivered to Distributor will perform in accordance with the Manufacturer's published specifications, and as outlined in the Manufacturer's booklet entitled "Thirteen Months Parts Only Limited Warranty" for thirteen months from date of shipment in Long Beach, MS. Distributor acknowledges that it has received a copy of such booklet, that it has read its entirety and that it understands and agrees with its contents.

Manufacturer's warranty shall not apply to any damage resulting from abuse, negligence, accident, or to any loss or damage to the products while in transit.

Written notice and explanation of circumstances surrounding any claims that the goods have proved defective in material or workmanship shall be given promptly from the distributor to the manufacturer. No claim may be made, or action brought, by or through a distributor after the expiration of 14 months following any alleged breach of warranty.

**DISTRIBUTOR'S SOLE AND EXCLUSIVE REMEDY IN THE EVENT OF DEFECT IS EXPRESSLY LIMITED TO THE REPLACEMENT OR CORRECTION OF SUCH DEFECTIVE PARTS BY MANUFACTURER AT ITS ELECTION AND SOLE EXPENSE, EXCEPT THERE SHALL BE NO OBLIGATION TO REPLACE OR REPAIR ITEMS WHICH, BY THEIR NATURE, ARE EXPENDABLE.** If Manufacturer is unable to replace or repair the defective parts, Manufacturer shall refund to Distributor that portion of the purchase price allocable pays to such goods.

No representation or other affirmation of fact not set forth herein, including but not limited to statements regarding capacity, suitability for use, or performance of the goods, shall be or be deemed to be a warranty or representation by Manufacturer for any purpose, nor give rise to any liability or obligation of Manufacturer whatever.

**EXCEPT AS SPECIFICALLY PROVIDED IN THIS DOCUMENT, THERE ARE NO OTHER WARRANTIES EXPRESSED OR IMPLIED INCLUDING, BUT NOT LIMITED TO, ANY IMPLIED WARRANTIES OR MERCHANTABILITY OR FITNESS FOR A PARTICULAR PURCHASE.**

**LIMITATION OF LIABILITY**

**IN NO EVENT SHALL MANUFACTURER BE LIABLE FOR LOSS OF PROFITS OR INCIDENTAL, INDIRECT, SPECIAL, CONSEQUENTIAL OR OTHER SIMILAR DAMAGES ARISING OUT OF ANY BREACH OF THIS CONTRACT OR OBLIGATIONS UNDER THIS CONTRACT.**

**DEFENSE OF INFRINGEMENT CLAIMS**

If notified promptly in writing of any action (and all prior claims relating to such action) brought against the Distributor based on a claim that Distributor's use of the goods infringes a patent or other intellectual property right, and if given access by Distributor to any information distributor has regarding such alleged infringement, Manufacturer agrees to defend Distributor in such action at its expense and will pay any costs or damages finally awarded against Distributor in any such action, provided the Manufacturer shall have had sole control of the defense of any such action and all negotiations for its settlement or compromise.



---

## WARRANTY / REPAIR POLICY

---

In the event that a final injunction shall be obtained against the Distributor's use of the goods or any of their parts by reason of infringement of a patent or other intellectual property right or if in Manufacturer's opinion the goods are likely to become the subject of a claim of infringement of a patent or other intellectual property right, Manufacturer will, at its option and at its expense, either procure for the Distributor the right to continue using the goods, replace or modify the same so they become non-infringing or grant the Distributor a credit for such goods as depreciated and accept their return. The depreciation shall be an equal amount per year over the lifetime of the goods as established by Manufacturer.

Manufacturer shall not have any liability to the Distributor under any provision of this clause if any infringement, or claim thereof, is based upon: (i) the use of the goods in combination with other goods or devices which are not made by Manufacturer; (ii) the use of the goods in practicing any process; (iii) the furnishing to the Distributor of any information, data, service, or applications assistance; or (iv) the use of the goods with modifications made by the Distributor. The Distributor shall hold Manufacturer harmless against any expense, judgment or loss for infringement of any patent or other intellectual property right which results from Manufacturer's compliance with the Distributor's designs, specifications or instructions. No costs or expenses shall be incurred for the account of Manufacturer without the written consent of Manufacturer. **THE FOREGOING STATES THE ENTIRE LIABILITY OF MANUFACTURER WITH RESPECT TO INFRINGEMENT OF PATENTS OR OTHER INTELLECTUAL PROPERTY RIGHT BY THE GOODS OR ANY PART THEREOF, OR BY THEIR OPERATION.**

### INTERPRETATION AND OTHER PAROLE EVIDENCE

This writing is intended by the parties as final expression of their agreement and is intended also as a complete and exclusive statement of the terms of their agreement. No course of prior dealing between the parties and no usage of the trade shall be relevant to supplement or explain any term used in these terms and conditions. Acceptance or acquiescence in a course of performance rendered under these terms and conditions shall not be relevant to determine the meaning of these terms and conditions even though the accepting or acquiescing party has knowledge of the performance and opportunity for objection. Whenever a term defined by the Uniform Commercial Code, as adopted in Mississippi, is used in these terms and conditions, the definition contained in the code is to control.

### MODIFICATIONS

These terms and conditions can be modified or rescinded only by writing signed by both the parties or their duly authorized agents.

### WAIVER INEFFECTIVE

No claim or right arising out of or relating to a breach of these terms and conditions can be discharged in whole or in part by a waiver or renunciation of the claim or right unless the waiver or renunciation is supported by consideration and is in writing signed by the aggrieved party. Waiver by either Manufacturer or Distributor of a breach by the other of any provision of these terms and conditions shall not be deemed a waiver of future compliance therewith, and such provisions shall remain in full force and effect.

# MODEL 9100 USER MANUAL

---

## STATUTE OF LIMITATIONS

Any action by the Distributor or Manufacturer for breach of these terms and conditions must be commenced within one (1) year after the cause of action has accrued.

## APPLICABLE LAW

These terms and conditions shall be governed by and construed in accordance with the provisions of the Uniform Commercial Code as adopted by the State of Mississippi.

## BANKRUPTCY

In the event of any proceedings, voluntary or involuntary, in bankruptcy or insolvency by or against Distributor, or in the event of the appointment, with or without the Distributor's consent, of an assignee for the benefit of creditors or of a receiver or of a liquidator, then Manufacturer shall be entitled to cancel any unfulfilled part of these terms and conditions without any liability whatsoever.

## PARTS ONLY LIMITED MANUFACTURER'S WARRANTY

Triton Systems of Delaware, Inc. warrants the components of each FT7000 ATM, excluding software and related documentation, against any defect in materials and/or workmanship for a period of 13 months from the shipping date. If a component fails due to defects in materials and/or workmanship within the warranty period, Triton will furnish a new or refurbished component, at its discretion. Triton shall not be responsible for labor or other costs associated with installing the components and the failed component shall be returned to Triton at the purchaser's expense. Triton shall not be responsible for misuse or abuse of a unit and any attempts to remove or deface the serial number or date code on a unit or any component thereof, or any attempt to repair a unit or to repair or replace any component by anyone other than a service technician authorized by Triton shall void this warranty.

### **Limited Warranty covers normal use. Triton does not warrant or cover damage:**

- occurring during shipment of the equipment or components from or to Triton's facilities;
- caused by accident, impact with other objects, dropping, falls, spilled liquids, or immersion in liquids;
- caused by a disaster such as fire, flood, wind, earthquake, lightning, or other acts of God;
- caused by failure to provide a suitable installation environment for the equipment, including but not limited to, faulty wiring in the building in which the equipment is installed, installation in a facility with uncontrolled environmental conditions, failure to provide a dedicated electrical circuit on which the equipment operates, and/or lack of proper earth grounding for the equipment;
- caused by the use of the equipment for purposes other than those for which it was designed;
- resulting from improper maintenance;
- caused by any other abuse, misuse, mishandling, or misapplication.

---

## WARRANTY / REPAIR POLICY

---

Under no circumstances shall Triton or its suppliers be liable for any special, incidental, or consequential damages based upon breach of warranty, breach of contract, negligence, strict liability, or any other legal theory. Such damages include, but are not limited to, loss of profits, loss of revenue, loss of data, loss of use of the equipment or any associated equipment, cost of capital, cost of substitute or replacement equipment, facilities or services, downtime, purchaser's time, the claims of third parties, including customers, and injury to property.

### DISCLAIMER OF WARRANTIES

The warranty stated above is the only warranty applicable to this product. All other warranties, expressed or implied (including all implied warranties of merchantability or fitness for a particular purpose or quality of service), are hereby disclaimed. No oral or written information, or advice given by Triton, its agents or employees shall create a warranty or in any way increase the scope of this warranty.

### SHIPPING DAMAGE

All equipment is shipped Free On Board (FOB), Triton's facilities. The organization or individual who has purchased the equipment assumes responsibility for the equipment once it leaves Triton's facilities.

Should your equipment be damaged in the process of shipment or delivery to your place of destination, we recommend the following course of action:

- If possible, call the shipping company before the driver leaves your delivery site. Make note of the damage on the "receipt of delivery" paperwork. If this is not possible, call them as soon as possible to report the damage.
- Take photographs of the damaged packaging prior to opening the boxes. If this is not possible, make note of key points, such as whether the equipment is on a pallet, if the banding is intact, how the boxes are damaged, etc. Keep all of the packaging for inspection by the shipping company.
- If you unpack the equipment, take photographs of the damaged equipment. If this is not possible, make note of the damages.
- You must file a claim with the shipper for shipping damages immediately after reporting the damages.

Should you specify the carrier, we recommend that you explore with this chosen carrier the policies and procedures regarding shipping damage claims prior to selecting them as your preferred carrier.

If the equipment receives structural damage and is in an un-installable condition, Triton will work with you to arrange for a replacement unit to be shipped as soon as possible. The purchaser will be billed for the replacement unit. Triton's repair technicians will repair the damaged unit after it is returned to our facilities. We will credit the purchaser's account for the full purchase price of the damaged unit, minus the cost of returning the unit to "like new" condition. Under no circumstances does Triton authorize anyone to complete structural damage repairs in the field. Therefore, we will not ship primary structural parts, such as a cabinet head or main cabinet body for repair in the field.

# MODEL 9100 USER MANUAL

---

## AUTHORIZED INSTALLATION AND SERVICE PROVIDERS

Triton utilizes several nationwide and regional authorized third party maintenance providers. Triton recommends all ATMs be installed and serviced by service technicians certified by Triton. This includes authorized third party service technicians and technicians who have been factory trained by Triton to service ATM equipment. Installation or repairs attempted by unauthorized service technicians may void the warranty or warranty claims denied on the product.

Please contact Triton's Technical Services department at (800) 259-6672 for a list of our third party service providers and/or to obtain information on the requirements and procedures for becoming a certified Triton service technician.

## TRITON'S TECHNICAL SERVICES DEPARTMENT

The primary purpose of the Technical Services department is to provide assistance to customers in the operation, trouble shooting, and repair of equipment manufactured by Triton. A toll-free phone number (1-800-259-6672) is provided for convenience. The Technical Services department operates to serve our customers. The staff is trained to follow our policies and procedures to ensure fair and uniform treatment of all our customers.

## AUTOMATED VOICE MAIL SYSTEM

Our goal is to have a 'live' person answer 100% of all incoming calls (during regular support hours). On occasion, however, call loads may exceed the capacity of the staff. When this occurs, an automated voice mail system will answer the call, indicate to the caller that all Technical Support specialists are busy assisting others, and ask the caller to leave detailed information about the nature of the call.

Should it become necessary to leave a voice mail message, the caller should state:

- their name,
- the organization for which they work,
- the **serial number** of the equipment they are calling about,
- detailed description of the problem that they are experiencing, and
- phone number where they can be reached, including area code.

As Technical Support specialists become available, they check for voice mail messages and return calls in the order in which they were received. By providing the information requested in the voice mail, the technician can be prepared when your call is returned. Triton asks you to be patient if you must leave voice mail and assures you that your call is important to us and that we will respond promptly.

# WARRANTY / REPAIR POLICY

---

## CALLS FOR SERVICE OR REPAIR

Calls for service or repair will be accepted from authorized service technicians only. End users must contact either the sales organization that placed the equipment or an authorized third party service organization to obtain service. The sections that follow describe the policies and procedures that relate to the repair and replacement of malfunctioning equipment.

## QUESTIONS ON OPERATION OF EQUIPMENT

Technical support is available to owners of Triton equipment and to qualified service personnel. When calling for help with the configuration or operation of a Triton product, the caller must provide either positive identification as a service technician or the serial number of a Triton terminal. Technical support is provided during normal business hours for the life of the product.

When calling for help with an operational problem, please have available information pertaining to the nature of the trouble. This includes the type of equipment, examples of what is or is not happening, and the name of the processor that supports your terminal.

All questions pertaining to the settlement of accounts, transaction inquiries, and fund status must be directed to the processor. Triton does not have access to the information needed to answer questions relating to specific transactions.

## CONTACT INFORMATION

Triton Systems of Delaware, Inc.  
522 East Railroad Street  
Long Beach, MS 39560

### SALES:

1 (800) 367-7191  
1 (228) 868-1317  
1 (228) 868-0437 (Fax)

### SERVICE:

1 (800) 259-6672 (Technical Support)  
1 (228) 575-3229 Fax (Technical Support)  
1 (228) 868-0859 Fax (Parts)

**THIS PAGE INTENTIONALLY LEFT BLANK**

**APPENDIX B**  
**COMBINATION LOCKS**

## INTRODUCTION

The security cabinet can be secured using either a mechanical or electronic combination lock. This appendix covers how to change the combination of either lock. Procedures specific to the electronic lock, such as changing the battery, are also covered. The first section covers the Mechanical combination lock.

## OPERATING THE MECHANICAL LOCK

### UNLOCKING THE LOCK

There are two marks on the dial ring (see drawing opposite page). The index at the top is used for opening the lock, The index 30 degrees to the left is used only when changing the combination.

The dial should always be turned slowly and evenly. A revolution is counted each time the selected number is aligned with the opening index. ***Do not turn the dial back to compensate for over-dialing a number.*** If, when dialing the combination, any number is turned beyond the index, the entire sequence must be repeated.

Locks are shipped on a factory setting of '50'. Using the '**Opening Index**', to unlock, turn the dial to the left (counterclockwise) four (4) turns, stopping on '50'. Then, turn the dial to the right until the dial stops. The combination lock bolt will retract and the safe door may be opened.

Unlocking 3-number combinations (For Example, "50-25-50")

1. Turn the dial to the ***Left*** at least four (4) complete turns to clear the combination lock to accept the combination.
2. Using the '**Opening Index**', turn the dial to the ***Left***, stopping when '50' is aligned with the opening index, the ***Fourth*** time.
2. Turn the dial to the ***Right***, stopping when '25' is aligned with the opening index, the ***Third*** time.
3. Turn the dial to the ***Left***, stopping when '50' is aligned with the opening index, the ***Second*** time.
4. Turn the dial slowly to the ***Right*** until the bolt retracts.

### LOCKING THE LOCK

Turn the dial to the ***Left*** at least four full revolutions.



## COMBINATION LOCKS

---

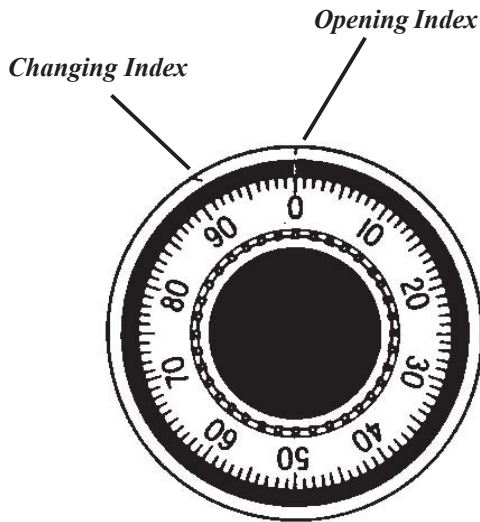

### Changing the Combination

#### CHANGE THE COMBINATION:

To change the combination, you will need access to the existing combination and a change key. First, open the safe door by dialing the existing combination. With bolt retracted and before changing combination, verify that the dial stopped between 90 and 100 on the '*Opening Index*'.

Select three new numbers. **DO NOT** use any number between **1 and 20** for the last number.

For maximum security, do not use numbers that end in 0 or 5, and do not use numbers in sequence: e.g., '27-48-86' is not as good as '27-86-48". Perform the following steps next:

1. Dial the existing combination again using the '*Change Index*', but **STOP** the dial on the last number of the combination.
2. With the last number set at the changing index, hold the dial securely and insert the change key in the keyhole in the back of the lock. Make sure the wing is entirely inside the lock and comes to a positive stop (see Figure 1) before turning the key.

***Note: If the change key will not go in, the wheels are not lined up to be changed and you must dial the combination again on the Change Index.***

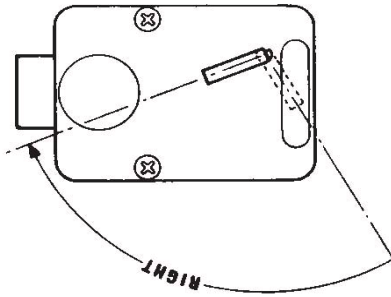

Figure 1.

3. Turn change key to the **Left** until it stops (approximately one-quarter turn). With the change key in this position, set the new combination as follows: **Note: Never select a number from 0 to 20 (the forbidden zone) as the last number of the combination.**
4. Using the '**Change Index**', turn the dial to the **Left** stopping when the first number of the new combination aligns with the '**Change Index**', the **Fourth** time.
5. Turn dial to the **Right**, stopping when the second number is aligned with the '**Change Index**', the **Third** time.
6. Turn the dial to the **Left**, stopping when the third number is aligned with the '**Change Index**', the **Second** time. Holding the dial in this position, turn the change key back to the **Right** and remove it. (See Figure 1.) The new combination you have chosen is now set in the lock,

**\*Important\***

**Before closing the vault door, try the new combination several times using the 'Opening Index'.**

---

## COMBINATION LOCKS

---

### OPERATING THE ELECTRONIC LOCK

The electronic lock combination consists of six digits. Upon arrival, the combination of the lock should already be preset to **1-2-3-4-5-6**.

#### ENTERING THE COMBINATION

1. Enter the preset combination and check for proper operation. After each keypress, the lock will beep. After the final digit has been entered, the lock will beep **twice**, and the open period will begin.
2. When a valid combination has been entered, the operator will have approximately **4 seconds** to open the lock.
3. To open the lock, turn the **dial** clockwise.
4. After the lock is opened, the cabinet door may be opened.

#### LOCKOUT FEATURE

The lock includes a '**Wrong Try Penalty**' lockout feature that prevents entry from unauthorized personnel. This feature performs as follows:

- Entry of four (4) consecutive invalid combinations starts a 5-minute delay period.
  - LED flashes red at ten (10) second intervals.
- At the end of the delay period, two (2) more consecutive invalid combinations will restart an additional 5-minute delay.

#### CHANGING THE COMBINATION

To change the combination of the lock, simply follow these directions.

1. Enter **six (6) zeros '0'**.
2. Enter the **current** combination (initially set at 1-2-3-4-5-6).
3. Enter the **new** six (6) digit combination **twice**.
  - If a mistake is made, wait thirty (30) seconds and repeat the first 3 steps.
4. Test lock combination several times before closing the door. The combination is now changed.

**Valid Code Entry** - Double signal after valid six (6) digit code is entered.

**Invalid Code Entry** - Triple signal and old code is still valid.

### BATTERY LOW WARNING

Repeated beeping during an opening indicates that the battery is low or dead and needs to be replaced. The battery box is located on the inside of the door.

**Note:** If the lock will not operate (i.e. repeated beeping or no beeping) while the door is closed and locked, the battery must be energized from the two external terminals on the front of the push-button panel.

To energize the lock, connect a 9-volt alkaline battery on the external terminal points. Maintain contact, enter a valid combination, and turn the dial clockwise to open the lock.

**Note:** *You must maintain battery contact at all times throughout this procedure.*

### CHANGING THE BATTERY

1. Open the ATM vault door. Remove the battery box cover by pulling the front portion away from the vault door.
2. The connector is easily removed by unsnapping it from the two (2) terminal on the top of the battery.
3. Remove the old battery. Install/connect a new 9-volt alkaline battery.
4. Push the battery and the leads completely up into the battery compartment.
5. Reinstall the cover and test the unit several times before closing the vault door.

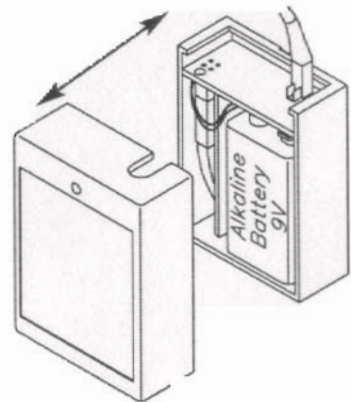

**APPENDIX C**  
**TRITON DISPENSING MECHANISM**  
**“BACKGROUND PAPER”**

## BACKGROUND PAPER

### TRITON DISPENSING MECHANISM (TDM)

1. The TDM dispenser family was designed and built to provide quality performance with minimum service. In 2005, Triton released two new versions of TDM dispensing mechanisms: the TDM-2XX multi-cassette family and a modified version of the TDM-1XX that included the features and improvements of the multi-cassette models.
2. The TDM-1XX modified dispenser mechanisms include a DC drive motor to replace the stepper motor for added control and a new pulley system that increases speed for improved note delivery. Changes in the diverter belt idler rollers and new belt material extend the life of the mechanism. The modified dispenser includes more self-diagnostic capability, expanded hardware error reporting to include cable disconnects, and an enhanced timing sequence to minimize jams. Firmware changes have made possible higher operation speeds and faster internal diagnostics.
3. There are two versions of TDM-1XX dispensers currently available, TDM-100/150 mechanisms produced before May 2, 2005 and the TDM Modified used in production since that date. A quick visual check of the drive motors can help determine the dispenser type and is illustrated in the photos below. The original TDM dispenser will have a black encased stepper motor installed next to the dispenser mainboard. The DC drive motor on the TDM modified is silver in color.

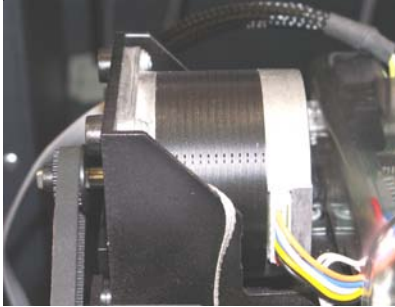

*Stepper Motor from original TDM-1XX*

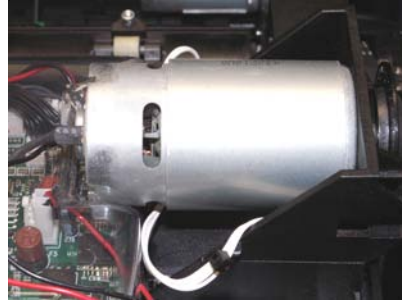

*DC drive motor from TDM-1XX modified*

- a. The DC drive motor used on the TDM-1XX modified will allow more efficient operation over the life of the product. This motor has a different sound than the stepper motor previously produced. One characteristic of this motor, though not readily noticeable in all of them, is the potential to produce a clicking sound not heard with the stepper motors. This has led some customers to believe there might be a problem with the dispenser. With the cabinet door closed this sound should not be immediately noticeable by ATM customers.

## TDM BACKGROUND PAPER

- b. Severe noise from any dispenser is an indication that a malfunction has occurred. If this happens you should examine the mechanism to determine the problem. Severe noise is normally caused by a drag on the mechanism, most likely from a shaft that has been pushed out of position causing the belt to “skip” on a pulley. This skipping is normally evident on the first two pulleys after the drive motor. In most cases the problem can be resolved by snapping the shaft back into position and if necessary replacing the top two drive belts. The part number for the belt replacement kit is 06100-00322 (TDM Belt Replacement Kit). See table below for kit breakdown.

TDM Belt Replacement Kit (P/N 06100-00322)			
Tools Required: #20 Torx driver / Phillips screwdriver			
Part Number	Description	Motor Type	Mechanism(s) Affected
03114-00001	Belt, Upper (short)	All	All listed below
04006-01001	Belt, Drive Motor (long)	DC (Stepper)	TDM-100 (w/o Billfish) TDM-150 (w/o Billfish)
04006-01003	Belt, Drive Motor (long)	DC (w/timing wheel)	TDM-100 (w/ Billfish) TDM-150 (w/ Billfish) TDM-200 (all) TDM-250 (all)
07100-00057	TDM Belt Replacement Procedures		

4. The pick mechanism for the TDM is located in the cassette. Failure to pick properly can cause the mechanism to exhibit symptoms of other dispenser errors.

As with any electro-mechanical device, there will be occasions when a malfunction or physical damage occurs and a repair is required. Failure to pick properly can cause the mechanism to exhibit symptoms of other dispenser errors. To accurately diagnose these errors it is necessary to have the mechanism and cassette operating together as a unit.

- a. If it becomes necessary to return a TDM dispenser to Triton for repair or replacement, the **Mechanism, Cassette(s), and Reject must be returned as a complete unit.**
- b. TDM dispensers can not be ordered as advanced replacement parts without the cassette and reject. RMAs for return will now include all three items. Failure to return the mechanism, cassette and reject together could result in repair or credit delays.

## OPENING THE ACCESS DOORS

1. The access doors allow you to check for jammed notes at key points in the feed path. The figures below shows the location of the lower, middle, and upper access doors on the front of the mechanism and the inner door located on the inside of the the dispenser (note and reject cassette(s) have been removed).

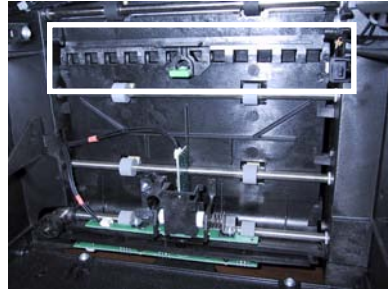
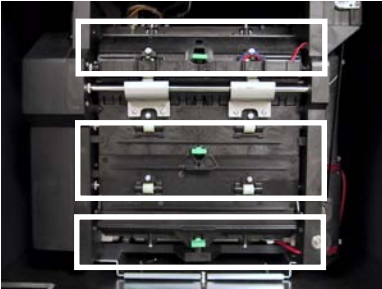

2. Each door is held closed using a **plastic fastener knob**. Note the position of the knob when a door is locked: the knob is **Horizontal** as shown in figure below.

3. To unlock a door, grasp that door's knob and **GENTLY** turn it a quarter-turn to the left or right (to the Vertical position shown in figure below). This will allow the door to be opened so any stuck/jammed notes can be retrieved.

*LOCKED*

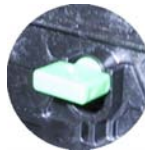

*UNLOCKED*



4. Carefully lift the door(s) to expose the feed path and remove any notes. Close the door. Apply gentle pressure to the door to hold it in place and **GENTLY** twist the **fastener** a quarter-turn to the left or right to lock the door in place.

*Knob shown in LOCKED and UNLOCKED Positions.*

**\*\* CAUTION \*\***

**The plastic fasteners ARE NOT HANDLES! They may pull out if you grasp them as such. Also, DO NOT force the knob to lock/unlock. You may break or damage!**



**SUPPLEMENT A**  
**(8100 / 9100 ATM)**  
**US/MEXICO**  
**(MAR, 06')**

## NEW CHANGES IN MANAGEMENT FUNCTIONS

The following describes new changes implemented in the latest (Mar, 06) 8100/9100 US/Mexico software release.

This supplement outlines all changes made to the software. This software release also pertains to the Model 8100 terminal software, providing a single load file for updating 9100 or 8100 terminals. New functionality included in this supplement includes:

1. User Defined Surcharge Screens
2. Configurable Currency Symbol
3. Enhanced Print Error Management
4. Improve logging of power failures during dispense
5. Check for TDM-100 protocol before TDM-200

## USER DEFINED SURCHARGE SCREEN SUPPORT

The functionality is designed to give the terminal owner the ability to create a screen to display surcharge information. This screen can be created from the terminal in Management functions or in Triton Connect 4.3 and downloaded to the terminal.

The User Defined Surcharge (UDS) screens are a free form way of entering whatever text the owner wants displayed as the surcharge message. This functionality is standalone and does not work in conjunction with any other surcharge functionality that dynamically determines what may or may not be displayed on the terminal, unless it is explicitly stated in this document. The common functionality supported by UDS includes: the ability to be displayed at the beginning or end of the transaction process and displaying the surcharge amount or percentage defined in the terminal, if the necessary parameters are entered as part of the UDS text. This common functionality will be described in greater detail later in this section.

### EDITING

UDS screens can be enabled, created, deleted, and modified at the terminal and using Triton Connect.

## SUPPLEMENT A

### MANAGEMENT FUNCTIONS

Access to editing UDS screen files is achieved using the following method. *Note: Only screens that have changed or have the potential to display new information will be shown.*

Select **CONFIGURE TERMINAL > MORE > CHANGE MESSAGES > SURCHARGE MESSAGES > MORE > MORE > USER DEFINED** to get to the following screen.



The terminal software will retrieve the primary language screen and display it on the terminal screen. If there is no screen file saved the display will be blank.



Once on the editing screen, the **Right (>)** and **Left (<)** arrow keys can be used to move around on the display. The cursor will move to the next line automatically when it reaches the end of the current line and wrap back to the beginning of the first line when it reaches the end of the last line on the screen. Entering new text will write over the current text. The new file is not saved until the **<Enter>** key is selected after the changes are made. If changes are made and the **<Cancel>** button is selected, the file won't change.

## MODEL 9100 USER MANUAL

If the screen times out due to inactivity, the file won't change. If you select "yes" on the timeout screen, the last saved UDS screen (or blank if no UDS screen was previously saved) will be re-displayed but all of the entered text will be lost. The US/Mexico file supports only English and Spanish as language options. English is the primary language and Spanish is the secondary language. English language text should be entered on this screen because this screen will be displayed when English is the selected language.

### NOTICE!!

**The text entered on this screen will be displayed as entered!  
If no text is entered a BLANK screen will be displayed during the transaction, if incorrect text is entered incorrect text will be displayed on the screen during a transaction!**

If <Cancel> is selected, the adjoining screen will be displayed for 3 seconds prior to continuing to the secondary screen. This screen indicates that if any text was entered it has **NOT** been saved. Also, the User Defined surcharge type has **NOT** been activated as the current surcharge type.

```
NO CHANGES SAVED
FOR
ENGLISH
USER DEFINED
SURCHARGE MESSAGE
```

Once <Enter> is selected or the 3 second timeout on the previous screen expires, the secondary screen, will be displayed, if there is a screen file for the secondary language.

```
SPANISH
CON TARJETA DE DEBITO INBURSA
NO TIENEN COSTO LAS
TRANSACCIONES. CON TARJETA DE
CREDITO INBURSA SE LE COBRARA
EN RETIROS EL CC%
INBURSA DEDUCIRA DE SU CUENTA
$$$$$.$$ POR DISPOSICION DE
EFECTIVO ESTA CUOTA ES ADICIONAL
A LA QUE SU BANCO PUEDA CARGARLE
ENTER TO SAVE, CANCEL TO EXIT
-----
F1-CENTER LINE
F2-CLEAR ALL LEFT---F6
F3-CLEAR LINE CENTER-F7
F4-CASE:UPPER RIGHT--F8
```

If there is no screen file for the secondary language, the screen will be blank.

## SUPPLEMENT A

The User Defined Surcharge type is now the active surcharge type. If <Cancel> is selected for the secondary language, UDS is still the active surcharge type. To eliminate the chance for error, enter a screen for every available language. Spanish language text should be entered on this screen because this screen will be displayed when Spanish is the selected language.

### NOTICE!!

**The text entered on this screen will be displayed as entered!**

If <Cancel> is selected, the following screen will be displayed for 3 seconds prior to exiting the UDS screen management section of Management functions. If there was no secondary screen previously saved, then the Spanish screen will be blank. If Spanish is ever selected as the transaction language and surcharging is turned on, the surcharge screen displayed will be blank.



This screen indicates that if any text was entered it has **NOT** been saved. If <Cancel> is selected for both English and Spanish screen, User Defined Surcharging is not active. If <Enter> is selected for either screen, User Defined Surcharging is active for both Spanish and English.

Once the UDS screen management section is exited, the screen prior to entering the English text-editing screen will be displayed. On this screen, the active surcharge screen type will be displayed.



## ENTERING TEXT

Follow the menu at the bottom of the editing screen to access different alphanumeric characters and symbols. The following tables define functionality and indicate what characters are accessed based on the function key that was pressed. The numeric characters are available by default. In order to get to alphabetic characters or special characters such as the dollar sign (\$), the function keys have to be used. The special characters are typed by setting the F4 function key to “lower”, and not selecting the F6, F7 or F8 function keys. Also, only the F4 function key stays resident, meaning that if uppercase is selected every subsequent key entry is in uppercase. But function keys F6, F7, F8 are only active for the subsequent key press. This means a function key( F6, F7, F8) always has to be selected prior to entering a key in order to get access at the letters.

<b>Function Key</b>	<b>Functionality</b>
F1	Centers the line of text on the screen that the cursor is currently on.
F2	Clears the entire screen
F3	Clears the line of text on the screen that the cursor is currently on
F4	Allows the user to select if the alphabetic characters are displayed in lowercase or uppercase.
F6	If this function key is selected an asterisk is displayed on the left of the LEFT text. The user can now enter alphabetic characters. Selecting left means you want to type the letter on the left of the key that is entered.
F7	If this function key is selected an asterisk is displayed on the left of the CENTER text. The user can now enter alphabetic characters. Selecting center means you want to type the letter on the center of the key that is entered.
F8	If this function key is selected an asterisk is displayed on the left of the RIGHT text. The user can now enter alphabetic characters. Selecting right means you want to type the letter on the right of the key that is entered.
Right Arrow	Moves the cursor one location to the right. Moves to the next line when the end of the current line is passed.
Left Arrow	Moves the cursor one location to the left. Moves to the previous line when the beginning of the current line is passed.

## SUPPLEMENT A

UPPER CASE								
1			2			3		
Q	Z	SPACE	A	B	C	D	E	F
4			5			6		
G	H	I	J	K	L	M	N	O
7			8			9		
P	R	S	T	U	V	W	X	Y
			0					
			.	.	.			

LOWER CASE								
!			@			#		
q	z	&	a	b	c	d	e	f
\$			%			^		
g	h	l	j	k	l	m	n	o
&			*			{		
p	r	s	t	u	v	w	x	y
			)					
			'	+	=			

### SPECIAL STRINGS

In order to keep the surcharge amount and percentage on the User Defined Surcharge screen in sync with the actual surcharge amount or percentage loaded in the terminal, there are two specialized strings that can be typed on the User Defined Surcharge screen. The terminal software will recognize these strings and replace the strings with the actual value.

**\$\$\$\$\$.SS** – When the terminal is displaying the User Defined Surcharge screen it will look for this string. When and if the special string is found, the software will replace the string with the surcharge amount. Supports values from 0 – 99999.99.

**CC%** – When the terminal is displaying the User Defined Surcharge screen it will look for this string. When and if this special string is found, the software will replace the string with the surcharge percentage. Supports values from 0 – 99

Strings must be typed exactly as listed, and they cannot be broken up over multiple lines.

## DISPLAYING

Depending on the language selected, the UDS screen will be displayed in the same location as the other surcharge screens. It can be configured to be displayed at the beginning of the transaction right after pin entry or at the end of the transaction after the amount is selected.

### NOTICE!!

**If the user defined surcharge screen was configured with no text, this screen will be blank.**

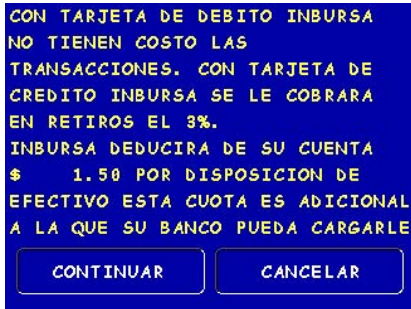

## ERRORS

Any errors retrieving UDS screen will result in the screen not being displayed and the terminal going “Out of Service”. The only situations that are considered errors are: the terminal detects a CRC error in the file or the terminal cannot find a valid screen file. The error code will be **(243)** and the description will be “Surcharge Screen Unavailable”





CONFIGURABLE CURRENCY SYMBOL

This is a feature that gives the user the capability of using 128 pre-defined characters as the symbol denoting currency. For instance, the dollar sign(\$) is the standard symbol in America for indicating money, however, many other countries use different characters. This feature is designed to give those other countries the flexibility of a greater number of symbol options.

Go to **CONFIGURE TERMINAL > CASSETTE SETUP**. Click on **INTERNATIONAL CURRENCY** to enter the currency symbol screen



Follow the directions on the screen to select and save the new currency symbol. The following screen lists all of the available currency symbols. Once the new symbol is selected and saved, all of the screens on the terminal that display a currency symbol will display the new symbol.



## ENHANCED PRINT ERROR MANAGEMENT

A new feature allowing the terminal to remain in service in the presence of print device errors accompanies this release. If configured to stay in service, the terminal will still perform transactions that do not require a receipt (withdrawals, purchases, etc.), in spite of an inoperable printer. This feature covers all printer errors including out of paper (it is not selective between error types). The terminal will not perform balance enquiries or transfer requests when the printer is unavailable. The customer is prompted with a notification of the terminal's inability to print a receipt allowing the opportunity to cancel the transaction.

Go to **CONFIGURE TERMINAL > PRINTER SETTINGS > PRINTER ERRORS**. When this option is selected, a screen will be displayed that enables the user to choose whether the ATM will remain "In Service" or go "Out of Service" when printer-related errors occur during normal transactions.

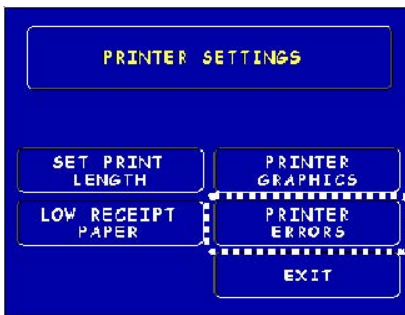

### Transaction Selection

If the option to stay "In Service" despite printer errors is *enabled* and a printer error is detected, the customer will be given the option to continue or cancel immediately after a Withdrawal or Purchase transaction is selected.



If the customer chooses to continue, no receipts will be printed and the terminal will **NOT** be taken out of service.

## SUPPLEMENT A

---

Also, Balance, Transfers and Mobile Phone Top-Up transactions will not be allowed. If the customer selects one of these transactions, a screen will be displayed informing the customer that the machine cannot give a receipt and that the transaction will not be allowed.



\*\*\* ATTENTION \*\*\*  
THE TERMINAL IS NOT CONFIGURED  
FOR THE SELECTED TRANSACTION.  
  
PLEASE SELECT  
ANOTHER TRANSACTION

If the printer stays “In Service” with a printer error and the transaction fails to dispense the correct amount, a screen is displayed indicated the result. The terminal then does a reversal.



UNABLE TO  
DISPENSE REQUESTED AMOUNT  
  
REQUESTED: \$ \_\_\_\_\_  
DISPENSED: \$ \_\_\_\_\_  
  
PLEASE WAIT  
ADJUSTING YOUR ACCOUNT

If the reversal fails, a screen is displayed indicating that the reversal failed.



\*\*\*ATTENTION\*\*\*  
  
UNABLE TO ADJUST YOUR ACCOUNT.  
  
PLEASE CHECK WITH YOUR  
FINANCIAL INSTITUTION.

### **IMPROVE LOGGING OF POWER FAILURES DURING DISPENSE**

In the case of a power failure during a dispense the terminal now logs the amount requested to be dispensed in the electronic journal.

### **CHECK FOR TDM-100 PROTOCOL BEFORE TDM-200**

When determining which type of TDM is attached, the terminal communicates to the dispenser using the old protocol first. If the older protocol is detected for the first time, then all the cassette structures will be cleared. Note that anytime a dispenser is changed, the software should be re-loaded.

**SUPPLEMENT B**  
**(8100 / 9100 ATM)**  
**CANADA**  
**(APR, 06)**

## NEW CHANGES IN MANAGEMENT FUNCTIONS

The following describes new changes implemented in the latest (Apr, 06) 8100/9100 Canadian software release.

This supplement describes additional features that make up this software. This software release also pertains to the Model 8100 terminal software, providing a single load file for updating 9100 or 8100 terminals.

1. TCP/IP Communication Support
2. SPED Support
3. TDM Support
4. 8100 APS Printer Support
5. CRC for Dial-up Communications
6. Terminal Setup Changes

### TCP/IP COMMUNICATION SUPPORT

This release adds TCP/IP over Ethernet support to the 9100. In the 9100 models, only one communication type is allowed for host communications.

### SPED SUPPORT

The 8100/9100 terminal software supports either the standard Triple DES EPP (Firmware version SP-01.04) or the Visa EPP (Firmware version VP-01.01).

### TDM SUPPORT

The Triton 9100 ATM system supports a variety of TDM dispenser mechanisms (TDM-100/150, TDM-200/250 etc.) with this release. The approach has been to provide a common dispenser-resident firmware package for all TDM dispensers, making the terminal SW interface common to all types.

For the dual feed channel TDM-2XX dispensers, cassettes A through C are available for configuration. Cassette D is not supported for any of the TDM dispensers and should appear grayed out on all management functions screens. The terminal immediately flags non-resident cassettes as out of service once the SW returns from management functions to customer transactions for multi-feed channel mechanisms.

Single feed channel dispensers such as the TDM-50 for the 8100 and TDM-1XX dispensers for the 9100 display only cassette A, all other cassettes will appear grayed out. The cassette type has a default setting of cash. They are automatically placed in service after boot. The “In-Service” configuration and status items do not apply to single feed channel dispensers. Only the value parameter requires configuration after a full load. TDM-50 dispensers are single “fixed bin” dispensers (no actual cassette). The terms cassette and bin may be used interchangeably in the scope of this supplement.

## SUPPLEMENT B

### 8100 APS PRINTER SUPPORT

The 8100 terminals are equipped with the APS CP MRS-250 printer. There is no extra setup required to use the printer, other than ensuring the EPROM is version KP01.03. The new terminal EPROM code provides the means for the terminal to detect and utilize the new print device. It should be noted that there is no graphics support with the APS print device. Receipt/coupon graphics cannot be printed to the device in this release. There are no management menu option changes to support this feature.

### CRC FOR DIAL-UP COMMUNICATIONS

A new feature allowing the terminal to send the 'ub' FID along with dial-up communications for message verification is included in this release. The feature defaults to disabled.

## TERMINAL SETUP CHANGES

### LOW-LEVEL MANAGEMENT MENU FLOW

The new features are accessible from the management menus as described in the following:

### MANAGEMENT FUNCTIONS MAIN MENU

With the TDM-2XX dispensers (multi-cassette), the entry-level management screen offers an option for placing cassettes into service. Placing cassettes into service is the only function this option allows, and will be addressed later in this supplement.

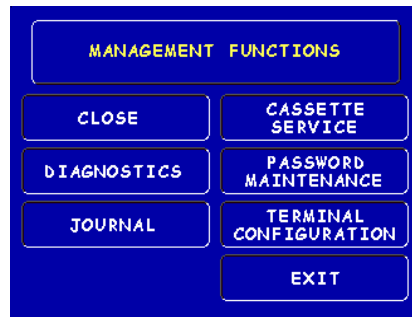

### TERMINAL CONFIGURATION

Selecting the Terminal Configuration option from the Main management functions menu allows customization of terminal features.

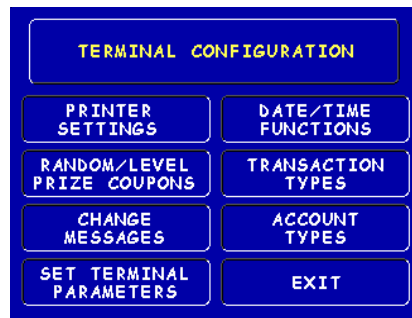

## SET TERMINAL PARAMETERS

This menu incorporates the configuration options for many terminal specific items. The items of interest accessible from this menu level for this release are Cassette Setup, Key Management, and TCP/IP over Ethernet Communication (both Host and Triton Connect) setup.



## HOST TCP/IP SETUP

With the induction of TCP/IP over Ethernet capable software the menu structure has been updated to include the options associated with the new communications type. This section details the Host TCP/IP over Ethernet options<sup>1</sup>.

## HOST TERMINAL COMMUNICATIONS

When selecting the “Communication” option from the “Terminal Parameters” menu, the user will be directed to the Host TCP/IP over Ethernet setup options. The new communication menu has the following appearance and maps directly to host communications:

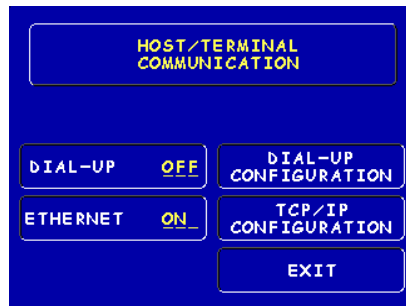

<sup>1</sup> Please note that the terms TCP/IP and Ethernet refer corporately to the new TCP/IP over Ethernet communications option. Technically, TCP is the transport protocol, IP is the Network layer protocol, and Ethernet is the Data Link and PHY layers. The installation and user guide reference may illustrate screen shots that say “TCP/IP” where the terminal displays “Ethernet”. These should be understood to be reference the same external TCP/IP over Ethernet external module.

## HOST TCP/IP CONFIGURATION

In this menu, the user can configure the network settings of the terminal and can test the TCP/IP.

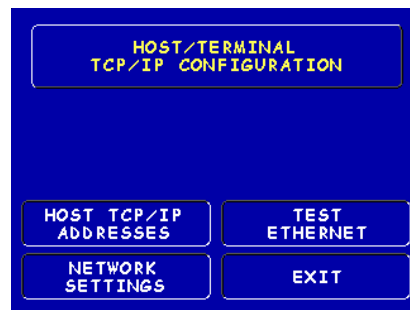



### NETWORK SETTINGS

This menu area allows for the terminal’s network settings to be configured. These settings are defined in Section 3, “TCP/IP Configuration” of this manual. Consult this reference for a complete description on TCP/IP over Ethernet configuration.

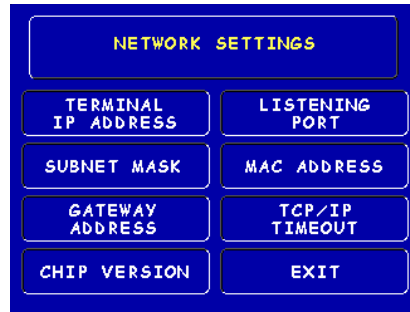

### TRITON CONNECT HOST SETUP

Triton Connect must be configured for use with the new TCP/IP over Ethernet interface as well. Setup begins from the menu path: **TERMINAL CONFIGURATION > SET TERMINAL PARAMETERS > MORE > TRITON CONNECT**. The following screens are displayed from the “**SET TERMINAL PARAMETERS > MORE**” screen.

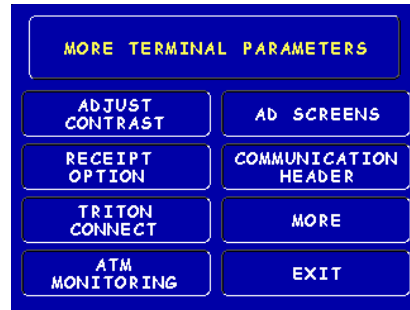

From here select **TRITON CONNECT**.

The “Ethernet” button is a status button that indicating the terminal is equipped with the external Ethernet module. This nullifies the dial-up option (should be grayed). From this screen, the “TCP/IP Configuration” option should be selected to enter the configure options for TCP/IP over Ethernet associated with Triton Connect, as detailed in Section 3, “TCP/IP Configuration” of this manual.



## TCP/IP OVER ETHERNET DIAGNOSTICS

This section describes the new diagnostic menus with this release. To get to the TCP/IP over Ethernet diagnostics, select the diagnostics option from the main menu:

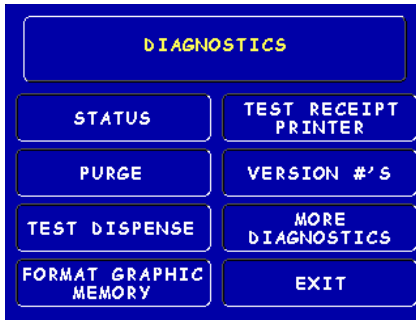

Select the “More Diagnostics” option to get:



Select the “Communications” option to get to the following screen:



The “Reset/Test Modem” selection option should be grayed out by virtue of the TCP/IP option’s availability. Selecting the “Test Ethernet” option forces the terminal to run a test on the External TCP/IP over Ethernet module and display the results. Again, refer to Section 3, “TCP/IP Configuration” of this manual. for details.

STANDARD KEY MANAGEMENT

The standard (Non-Visa EPP) key management menu flow is defined below. The “Key Management” options are accessed from the “Terminal Parameters” screen. See the Set Terminal Parameters section for details.

TERMINAL PARAMETERS

This menu screen allows for access to the key management menu items.



EXISTING KEY MANAGEMENT

This menu screen shows the non-VEPP key management options.



EXISTING KEY ENTRY

This menu prompts the user to specify which key they wanted to enter either the right or left key.



## EXISTING ENTER KEY

This menu described the key entry process to the user.

*\*NOTE – The key mapping for entering the alpha characters of the key block are described at the bottom of the screen.*

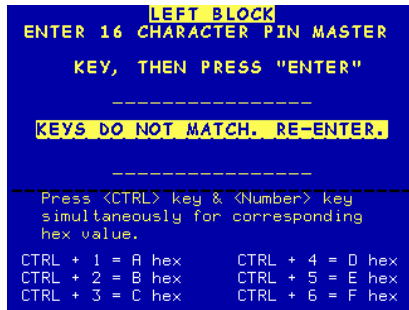

## KEY LOADED AND CHECK DIGIT VERIFICATION

This screen would display the check digits that were derived from loading the encrypted key.

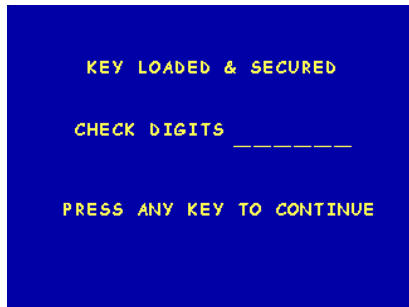

## VISA EPP KEY MANAGEMENT

With the inclusion of the Visa EPP support, the Key Management menu flow has changed to meet the Visa® specification. Those changes are as follows. This screen flow affects the key entry procedure in the Management functions. The VEPP must enforce Dual Control of encryption keys. The following screens will describe how this is accomplished.

## KEY MANAGEMENT



### ENTER IN PASSWORDS

This is a new screen that prompts the users to enter their Password so that the VEPP can verify each user. Two passwords are required to be entered by two separate persons to gain access to the sensitive instructions to the VEPP.



### CHANGE USER PASSWORDS

The VEPP requires that no default password or passwords can be entered and a user be able to change the master keys. If a user enters the default password, (six zero's '000000'), the VEPP will force the user to change the password or passwords before the option of entering in the master keys is displayed.

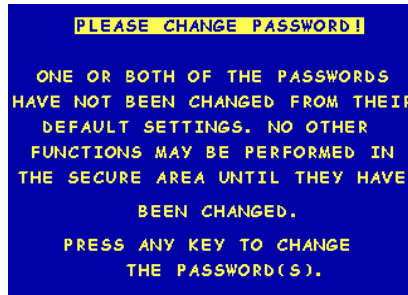

### CHANGE PASSWORD SELECTION

This is a screen that allows the user to select which password to change. If any password is the default value the VEPP will only allow the changing of the passwords. Once the default password or passwords have been changed, the access to the encryption keys functions will be allowed.

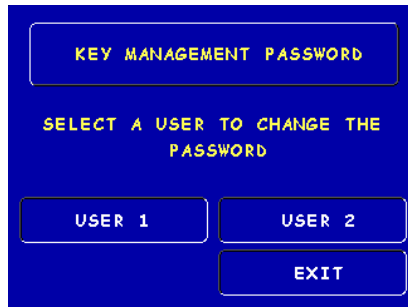

### CHANGE PASSWORD

This screen demonstrates the steps required to change a password in the VEPP.



## MAIN KEY MANAGEMENT SELECTION

This screen shows what functions are allowed when the VEPP is in dual control.



## ENTER (ANY) KEY

This menu selection is the same for each of the three different keys that can be entered.

*\*NOTE – This key maps to the current layout of a Triton Systems EPP. Since the encryption keys are hexadecimal strings, the EPP must allow for the alpha characters in the hexadecimal numbering system. The following describes the key mappings.*



*‘A’ maps to the ‘<’, ‘B’ maps to the ‘>’, ‘F’ maps to “CANCEL”, ‘E’ maps to “CLEAR”, ‘D’ maps to “ENTER”, and ‘C’ maps to the blank key.*

## ACCEPT THE KEY

Once the enter function key is selected, the user is prompted to either accept the key or not. The new VEPP requires that two key parts for each key be loaded. After this screen will be a screen to indicate that the second part must be entered. Then the Enter (ANY) Key screen will be displayed to load the second key part. After the second key part is loaded, the terminal will prompt if any additional key parts need to be loaded.



NEW VEPP TAMPER AND SERIAL NUMBER ERRORS

The way that VEPP Tamper and the new Serial Number errors are cleared at the terminal has changed to indicate to the terminal owner that the VEPP device may have been tampered or switched with a non-secure VEPP. This added security required the prompting of the terminal operator to read some screens to further emphasize the inspection of the VEPP device. If one of these errors occurs the following screen shots demonstrate the new way to clear it.

INITIAL ERROR SCREEN



If this error screen has either the VEPP tamper error number **205** or the VEPP Serial Number Error number **239**, the reset error button **will not** clear this error. The Terminal owner will have to traverse through Management functions to reset this error.

DIAGNOSTICS (KEYPAD)

This menu item is in the diagnostic menu structure. When the keypad is selected the items specific for the keypad diagnostic will appear.



## KEYPAD DIAGNOSTIC MENU

This menu is dynamic. The clear error codes (Tamper or Serial) will only appear when either error is detected on the terminal. The VEPP Status button will print a current status of the VEPP on to the screen with the option to print the data in a more detailed form.



## VEPP STATUS

This screen is completed by the status information that was received from the VEPP device. The Print option will give a receipt that has more detailed information.

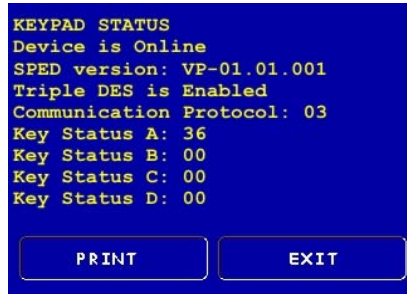

## CLEAR TAMPER

This option is only displayed if the terminal has detected a tamper condition from the VEPP device. Once the item is selected the terminal user will get the following screen describing what actions need to be taken.

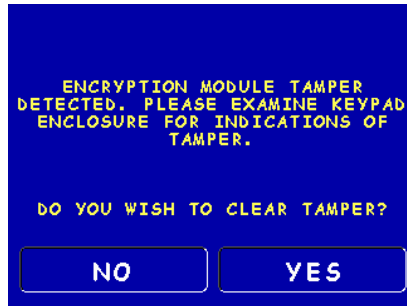

## CLEAR SERIAL TAMPER

This option is only displayed when the serial number of the VEPP device does not match the VEPP device serial number that the terminal has stored. This is not a VEPP device tamper but an indication that the terminal may have been tampered with. If this condition is detected the following screen is displayed when the Terminal user selects Clear Serial Tamper. When this error is cleared, the Serial number of the connected VEPP is written to the terminal.

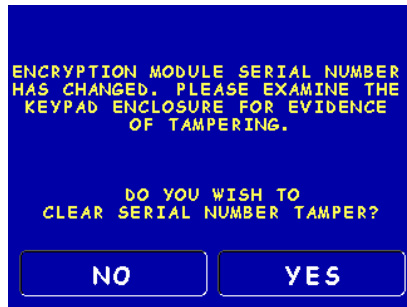



## TDM DEFAULT SETTINGS

The TDM dispenser comes with default settings as follows:

1. Each cassette type is designated as cash
2. Value (denomination) defaults to zero

During the boot procedure, terminals configured with a multi-feed channel terminal TDM will force an **Error Code 156** to ensure the user enters the cassette setup management functions to configure and put at least one cassette in service.

## TDM CONFIGURATION

New management screens and options accompany the introduction of the multi-cassette TDM. This section describes the management flow implemented to support configuring and managing both single and multi-cassette TDM mechanical dispensers. The following screens are defined to lead the user through the configuration process:

\* **NOTE** - Again, only cassette A is relevant to the 8100 terminals with the TDM-50 fixed bin dispenser and 9100 terminals configured with a TDM-100. All other cassette buttons (B-D) should be grayed out.

## TERMINAL PARAMETERS

This menu provides the options for entering cassette setup.



## CASSETTE SETUP

This screen provides the means to configure each of the cassettes available in the dispenser.

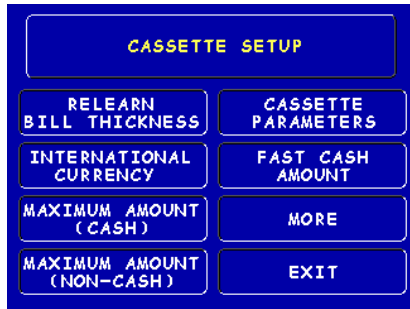

## RELEARN BILL THICKNESS

This menu option requests that the TDM resample the thickness averages for each cassette. The TDM dispenser will sample 9 bills (per cassette), dispensing them into the reject cassette. The following warning screen is displayed giving the user the option to abort prior to relearn commencement:

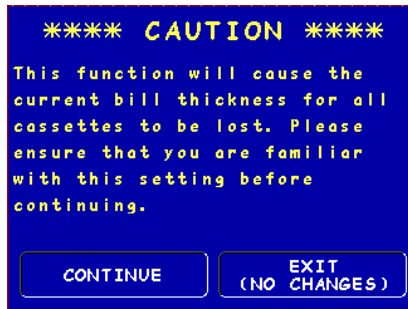

## INTERNATIONAL CURRENCY SYMBOL

The option to change the international currency symbol screen appears as follows. The customer can cycle through the available symbols by pressing the "Change Symbol" button repeatedly.



## MAXIMUM AMOUNT (CASH)

This option configures the maximum amount for any single cash withdrawal transaction.



### MAXIMUM AMOUNT (NON-CASH)

This screen allows the user to configure the maximum amount dispensed for the non-cash purchase feature. This value specifies the maximum for any non-cash purchase and must be divisible by the document value configured for the cassette (multi-feed channel dispensers only).

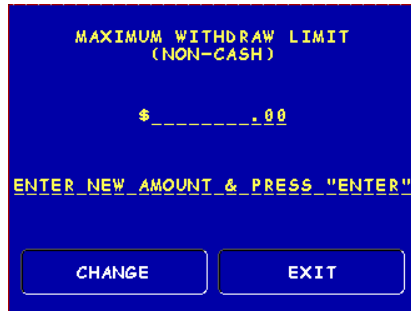

### CASSETTE SELECTION

Selecting “Cassette Parameters” from the “Cassette Setup” options displays the “Select Cassette” screen. This allows the user to select which cassette to configure. Note that the “CASSETTE LOCKING” feature does not apply to TDM dispensers and would be grayed out.

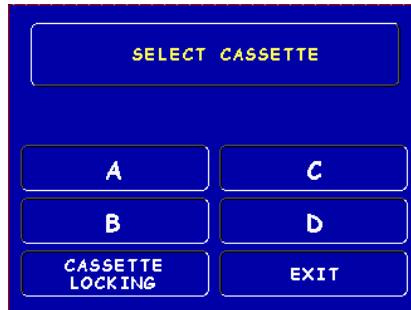

### CASSETTE PARAMETERS

This screen allows the user to modify the value, type, service state, and description parameters for a specific cassette (only value parameter can be set for single feed channel dispensers). The bill dimension and currency data parameters do not apply to the TDM dispensers and will be grayed out on this screen.

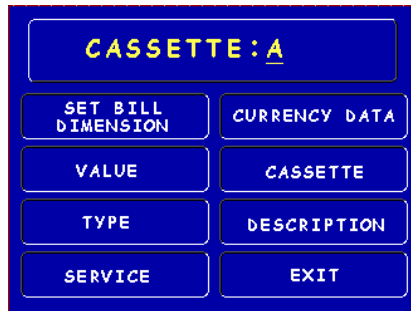

### VALUE PARAMETER

This option allows the user to configure the value associated with the selected cassette.



## TYPE PARAMETER

The type parameter option allows the user to setup the cassette as either cash or non-cash document type (multi-feed channel dispensers only). This option allows for non-cash purchases, coupon dispensing, etc.

DOCUMENT TYPE

TYPE: \_\_\_CASH

CASH NON-CASH

EXIT

## SERVICE PARAMETER

This screen displays the current cassette status and provides the option to place the cassette in service or take the cassette out of service (multi-feed channel dispensers only).

CASSETTE STATUS

OUT OF SERVICE

IN SERVICE OUT OF SERVICE

EXIT

## DESCRIPTION PARAMETER

The description parameter allows primary and secondary descriptions to be applied to the cassette when the non-cash purchase option for transactions is available (multi-feed channel dispensers only).

SELECT DESCRIPTION FIELD TO MODIFY

PRIMARY DESCRIPTION SECONDARY DESCRIPTION

EXIT

**TDM SERVICE MANAGEMENT**

The management functions include menus for placing cassettes in service, or taking them out (multi-feed channel dispensers only). The cassette service menu is provided at the lowest management functions screen level and is grayed out for single feed channel dispensers.

**CASSETTE SERVICE SCREEN**

Selecting the cassette service menu displays the following screen (multi-feed channel dispensers only):

The “Cassette Locking” feature does not apply to TDM cassettes. Each cassette (up to three) is displayed for selection from this screen, regardless of their presence/absence in the dispenser. This allows for pre-provisioning of cassettes prior to installation. Selecting cassette A through C (remember cassette D will be grayed out) from this menu places the cassette in service and displays the following screen if successful:

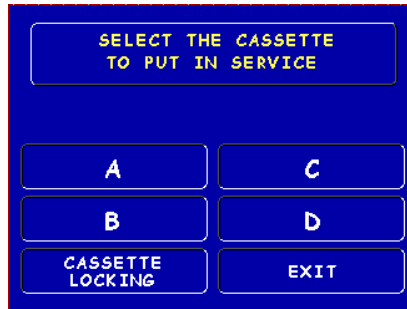

## TDM CASSETTE CLOSURE

The new feature includes menus for closing specific cassettes. From the main management functions menu, selecting the close option displays the following screen:

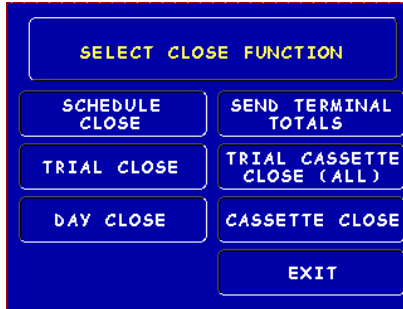

### CASSETTE CLOSE

From the close option the cassette close function can be selected offering the following options: \* **NOTE** - Selections B and C are grayed for single feed channel dispensers, D is grayed for all TDM dispensers.

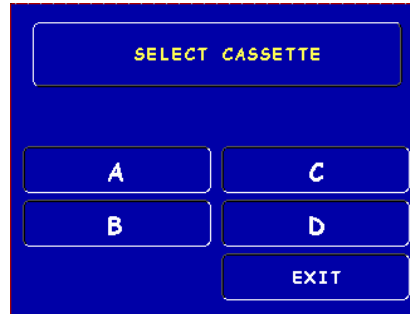

Choosing a cassette (A through C) will direct you to the next screen at right:

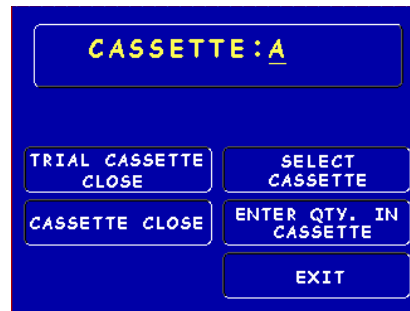

Selecting either the Trial Cassette Close or Cassette Close option initiates the close action for the selected cassette.

When “Trial Cassette Close” is selected, the results are printed, but none of the cassette counters are cleared. When the “Cassette Close” option is selected, the results are printed and all associated counters (documents dispensed, reject event counts etc.) are cleared.

**TRIAL CASSETTE CLOSE (ALL)**

When the trial cassette close all function is selected, the printed results include counts for all cassettes, and the “transaction is printing” screen is displayed until printing is complete. This option is grayed out for single feed channel dispensers.

**COUPON DISPENSING**

The TDM offers the option of selecting a cassette for the purpose of dispensing coupons. To configure the dispensed coupon feature, select the “Random/Level Coupon Prizes” option from the terminal configuration menu. This feature is only available for multi-feed channel dispensers. The following paragraphs describe the remaining setup procedures for achieving the correct configuration.

**DISPENSED COUPONS**

This is the screen that allows entrance into the dispensed coupon configuration options from the main coupon prizes menu. From here you must select “Dispensed Coupons” to configure the parameters for dispensing coupon prizes.



**RANDOM/LEVEL PRIZE COUPON CONFIGURATION**

This screen displays the options for configuring level and random dispensed coupons and enabling the coupon feature. Two types are supported; level and random prize awards. Each coupon type is slightly different.



**SELECT LEVEL COUPON CASSETTE**

This screen selects the cassette associated with the level prize award. It also indicates upon entry which cassette, if any, is currently selected (X indicates none is selected).

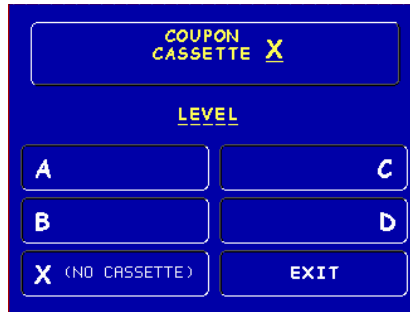

**SET LEVEL PRIZE AMOUNT**

Level coupons are awarded based on the amount dispensed. This screen allows the user to specify the withdrawal threshold that triggers the level prize award.



**SELECT RANDOM COUPON CASSETTE**

This screen selects the cassette associated with the random prize award. It also indicates upon entry which cassette, if any, is currently selected (X indicates none is selected).

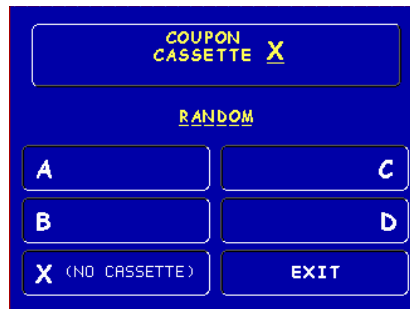

**SET RANDOM WINNING PERCENTAGE**

Random coupons are awarded in a random fashion based on the percentage configured. This screen allows the user to specify the withdrawal threshold that triggers the random prize award (from 0 to 100%).





### ENABLE/DISABLE COUPONS

The final step is to enable the dispensing of coupons from this menu. In addition to the other dispensed coupon configuration elements, the cassette selected for the coupons must be specified as non-cash with a value of zero before coupons will be dispensed.



### ENABLING CRC FOR DIALUP COMMUNICATIONS

Including CRC (the 'ub' FID) is standard for TCP/IP communications, but has now been added as an option for standard dialup communications as well. The option can be enabled/disabled by sending the following parameter update files:

1. 91CRCON.H – Turns option on
2. 91CRCOFF.H – Turns option off

**THIS PAGE INTENTIONALLY LEFT BLANK**

**SUPPLEMENT C**  
**(8100 / 9100 ATM)**  
**SOUTH AFRICA**  
**(MAY, 06)**

## NEW CHANGES IN MANAGEMENT FUNCTIONS

The following describes new changes implemented in the latest (May, 06) 9100 South Africa software release.

This supplement describes additional features that make up this software. This software release also pertains to the Model 8100 terminal software, providing a single load file for updating 9100 or 8100 terminals.

1. 8100 APS Printer Support
2. Enhanced Print Error Management
3. Default Recognition for EMV Card Reader
4. Key Inject

### 8100 APS PRINTER SUPPORT

The 8100 terminals are equipped with the APS CPMRS-250 printer. There is no extra setup required to use the printer, other than ensuring the EPROM is version KP01.03. The new terminal EPROM code provides the means for the terminal to detect and utilize the new print device. It should be noted that there is no graphics support with the APS print device. Receipt/coupon graphics cannot be printed to the device in this release. There are no management menu option changes to support this feature.

### ENHANCED PRINT ERROR MANAGEMENT

A new feature allowing the terminal to remain in service in the presence of print device errors accompanies this release. If configured to stay in service, the terminal will still perform transactions that do not require a receipt (withdrawals, purchases, etc.), in spite of an inoperable printer. This feature covers all printer errors, including out of paper (it is not selective between error types). The terminal will not perform balance enquiries or transfer requests when the printer is unavailable. The customer is prompted with a notification of the terminal's inability to print a receipt allowing the opportunity to cancel the transaction.

### DEFAULT RECOGNITION FOR EMV CARD READER

This load is sent with the flags modified to default to the EMV smart card reader. **It is important to note that terminals loaded with this SW will not function correctly with any other card reader installed.**

### KEY INJECT

The ability to use the PC Key inject program to load security keys into the terminal via the load port has been added to this version of software. This feature was in terminal software previously but was removed. It will work similarly to its previous operation, however, if a Visa EPP is loaded instead of a triple des SPED the key inject functionality will not be available.

## TERMINAL SETUP CHANGES

### LOW-LEVEL MANAGEMENT MENU FLOW

The new features are accessible from the management menus as described in the following:

### MANAGEMENT FUNCTIONS MAIN MENU

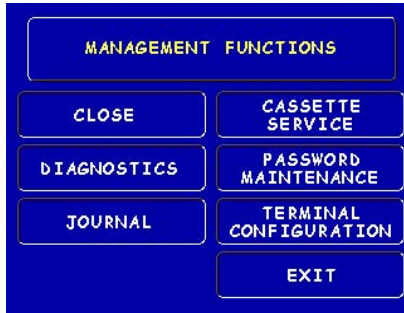

### TERMINAL CONFIGURATION

Selecting the Terminal Configuration option from the Main management functions menu allows customization of terminal features.

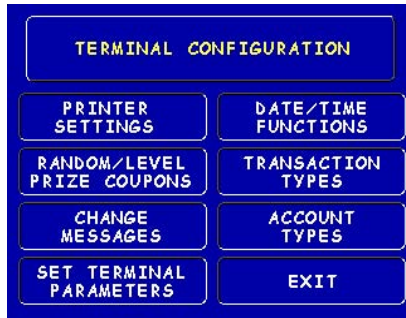

The features described next will be configured from the "PRINTER SETTINGS" submenu.

## ENHANCED PRINTER ERROR MANAGEMENT

This SW release includes an enhanced printer error management feature and is configured to remain in service by default. Enabling the feature to “ignore” printer errors does not change the accurate printer status reporting to the host through status monitoring or Triton Connect status reporting. The terminal will always report the correct current status of the print device in spite of the feature’s enabled/disabled status.

### CONFIGURING THE FEATURE

From the main terminal configuration screen, selecting the “**PRINTER SETTINGS**” button displays the following screen:

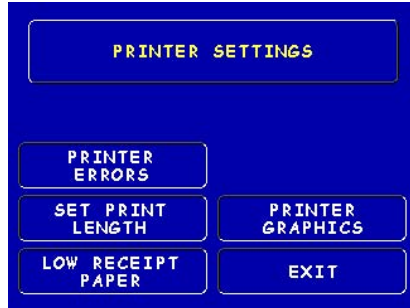

Selecting “**PRINTER ERRORS**” displays the next screen:

This allows the user to select between having the terminal go “Out of Service” when the printer encounters errors, or remain “In Service”. When the selection is made, the change is reflected at the top of the screen.



### TERMINAL RESPONSE TO PRINTER ERRORS

When the feature is disabled, the terminal will go out of service when a printer error is encountered, just as it always has. When the feature is enabled, the print device is inoperable and the customer selects a withdrawal or purchase transaction, the customer will see the screen notification:



For these types of transactions, the customer is allowed to proceed if they elect. When the feature is enabled, the print device is inoperable and the customer selects a transaction that requires a receipt (e.g. Balance Enquiry), the customer will see the screen notification:

The customer is not allowed to proceed under these conditions and is prompted to select a different transaction from the original transaction selection screen. The timeout between this screen and the menu for choosing a new selection is approximately 5 seconds.



**TERMINAL NOTIFICATIONS FOR  
TRANSACTIONS ERRORS**

When the feature for remaining in service with printer errors is enabled, the customer elects to continue with a withdrawal transaction (or purchase) without the print device, and a partial or no dispense event occurs, the customer will see the following recap screen:



This screen will be shown during the reversal process, indicating the amount requested and the amount actually dispensed. If the reversal fails, the following screen is shown directing the customer to contact their card-issuer:



## KEY INJECT

If the Visa EPP device is detected then the Key Management screen will appear as follows without the capability of executing Key Inject.



However, if a Triple DES SPED is detected, the following Key Management screen will be displayed.



When the INJECT MASTER KEY button is selected, the following screen will be displayed indicating that the key is being downloaded.

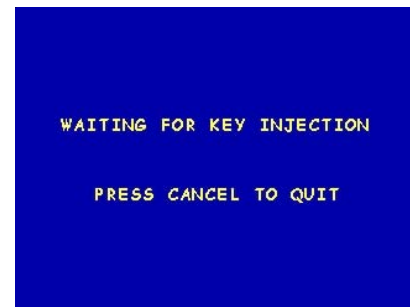

Once the Keys are downloaded, the check digits will be displayed indicating keys were downloaded successfully.





## SUPPLEMENT C

---

If the keys were 'NOT' downloaded successfully an error screen will be displayed.

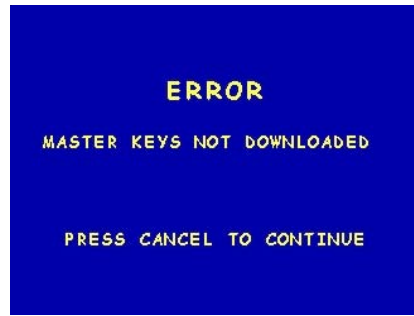

**THIS PAGE INTENTIONALLY LEFT BLANK**

**SUPPLEMENT D**  
**(8100 / 9100 ATM)**  
**US**  
**(FEB, 07)**

## NEW CHANGES

The following describes new changes implemented in the latest (Feb, 07) 8100/9100 US software release.

This supplement describes additional features that make up this software. This software release also pertains to the Model 8100 terminal software, providing a single load file for updating 9100 or 8100 terminals.

1. TDM Support
2. Fully Supports TDM-2XX Return Codes
3. Test Dispense with TDM-2XX Return Code Intact
4. Test for TDM-1XXs before TDM-2XXs
5. Correcting the Screen Flow for the Printer Off-Line Notification
6. Auto Recovery from 139 Printer Error (9100 only)
7. Default Password Detection

## TDM SUPPORT

The Triton 9100 ATM system supports a variety of TDM dispenser mechanisms (TDM-100/150, TDM-200/250 etc.) with this release. The approach has been to provide a common dispenser-resident firmware package for all TDM dispensers, making the terminal SW interface common to all types.

For the dual feed channel TDM-2XX dispensers, cassettes A through C are available for configuration. Cassette D is not supported for any of the TDM dispensers and should appear grayed out on all Management functions screens. The terminal immediately flags non-resident cassettes as “Out of Service” once the SW returns from Management functions to customer transactions for multi-feed channel mechanisms.

Single feed channel dispensers such as the TDM-50 for the 8100 and TDM-1XX dispensers for the 9100 display only cassette A, all other cassettes will appear grayed out. The cassette type has a default setting of ‘Cash’. They are automatically placed “In Service” after boot. The “In-Service” configuration and status items do not apply to single feed channel dispensers. Only the value parameter requires configuration after a full load. TDM-50 dispensers are single “fixed bin” dispensers (no actual cassette). The terms cassette and bin may be used interchangeably in the scope of this document.

**With this and future versions of 9100 software, when installing an update file over any prior software release on a terminal with a TDM50, TDM100, or TDM150 dispenser, the cassette multiple amount will need to be reconfigured before the terminal will go into service\*\*.**

**\*\*Note** - In this situation, if an update file is loaded from Triton Connect, the machine can only be put into service by configuring the cassette multiple amount in Management Functions at the terminal. Subsequent update loads will not require this step.

## SUPPLEMENT D

---

### FULLY SUPPORTS TDM-2XX RETURN CODES

This release fully supports the TDM-2XX return codes. There are two classes of return codes where one is a soft error that the terminal will accept and retry the failed command. The second class is a fatal error and will cause the terminal to not retry and go out of service with the error code.

### TEST DISPENSE WITH TDM-2XX RETURN CODE INTACT

The TDM-2XX reports a status of the test dispense operation. This release corrects the reporting of that status information.

### TEST FOR TDM-1XXS BEFORE TDM-2XXS

This release corrects the problem of newer TDM firmware that responds to both command sets of the TDM product line. These command sets changes the way that cassettes are managed and error codes that are reported. This release will test for a single cassette TDM before testing for a TDM multi-cassette mechanism.

### CORRECTING THE SCREEN FLOW FOR THE PRINTER OFF-LINE NOTIFICATION

The Printer off-line notification will now return the customer to the Transaction Cancelled screen then to the Welcome Screen when the No is selected or the screen exhausts its timeout waiting for input from the customer.

### AUTO RECOVERY FROM 139 PRINTER ERROR (9100 ONLY)

This maintenance release adds the capability to the terminal to auto-recover from an 139 error if possible. The 139 error condition indicates that the terminal experienced a problem with the printer. Previous releases required the Terminal Owner to restart the terminal and then reset the error. Now if the printer recovers from the error, the terminal will constantly test for this state and automatically reset the error and return into service. If paper was out when this error occurred, within 30 seconds of paper being reloaded, the terminal will go back in service.

### DEFAULT PASSWORD DETECTION

The terminal will no longer go into service if the Master and/or Administration passwords are configured in their default setting. A new error code (246) will be displayed when the passwords are in their default state. The terminal will detect this condition and go out of service. On the "Out of Service" screen, no error information will be displayed. The following are screen captures of this state. This error code will not clear until the Master and/or the Administration passwords are changed from their default state.

The default MASTER password is '123456' and the default ADMINISTRATION password is '987654'.

1. The following screen appears. Select MANAGEMENT option.



2. Enter the default MASTER password '123456'.

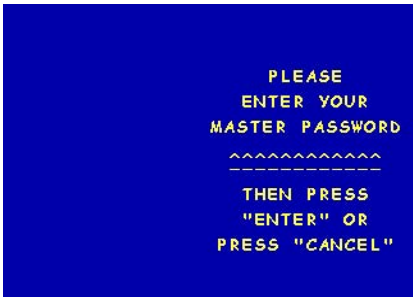

3. The following prompt appears. Select MANAGEMENT option.



4. The Main Menu appears. Select CONFIGURE TERMINAL (multi-host) or PASS-WORD MAINTENANCE.



5. Select PASSWORD MAINTENANCE.



## SUPPLEMENT D

6. Select **MASTER PASSWORD** option.  
Enter a new Master password.

**NOTE:** The terminal Master password consists of 4-12 digits (no characters).



7. Select **ADMINISTRATION PASSWORD** option. To view current Administration password, select **VIEW**.

To change the Administration password, select **CHANGE**. Enter a new Administration password.

**NOTE:** The Administration password consists of 4-12 digits (no characters).

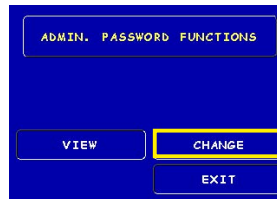
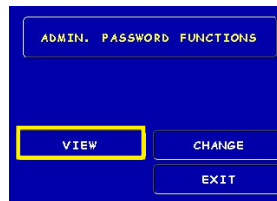

### ***\* NOTE \****

***If you use the same password for both the MASTER and ADMINISTRATION functions, the ATM defaults to the MASTER functions, the highest level options. Never use the identical password for both MASTER and ADMINISTRATION!***

8. Exit out of Management Functions. The password(s) have been changed. Enter the new Master or Administration password to enter Management functions.

**THIS PAGE INTENTIONALLY LEFT BLANK**



**SUPPLEMENT E**  
**(8100 / 9100 ATM)**  
**CANADA**  
**(MAR, 07)**

## NEW CHANGES

The following describes new changes implemented in the latest (Mar, 07) 8100/9100 Canada software release.

This supplement describes additional features that make up this software. This software release also pertains to the Model 8100 terminal software, providing a single load file for updating 9100 or 8100 terminals.

1. TDM Support
2. Fully Supports TDM-2XX Return Codes
3. Test Dispense with TDM-2XX Return Code Intact
4. Test for TDM-1XXs before TDM-2XXs
5. Auto Recovery from 139 Printer Error (9100 only)
6. CRC Validation Request and Response Messages
7. Default Password Detection
8. Changes to the Communication Specification

## TDM SUPPORT

The Triton 9100 ATM system supports a variety of TDM dispenser mechanisms (TDM-100/150, TDM-200/250 etc.) with this release. The approach has been to provide a common dispenser-resident firmware package for all TDM dispensers, making the terminal SW interface common to all types.

For the dual feed channel TDM-2XX dispensers, cassettes A through C are available for configuration. Cassette D is not supported for any of the TDM dispensers and should appear grayed out on all Management functions screens. The terminal immediately flags non-resident cassettes as “Out of Service” once the SW returns from Management functions to customer transactions for multi-feed channel mechanisms.

Single feed channel dispensers such as the TDM-50 for the 8100 and TDM-1XX dispensers for the 9100 display only cassette A, all other cassettes will appear grayed out. The cassette type has a default setting of ‘Cash’. They are automatically placed “In Service” after boot. The “In-Service” configuration and status items do not apply to single feed channel dispensers. Only the value parameter requires configuration after a full load. TDM-50 dispensers are single “fixed bin” dispensers (no actual cassette). The terms cassette and bin may be used interchangeably in the scope of this document.

**With this and future versions of 9100 software, when installing an update file over any prior software release on a terminal with a TDM50, TDM100, or TDM150 dispenser, the cassette multiple amount will need to be reconfigured before the terminal will go into service\*\*.**

**\*\*Note** - In this situation, if an update file is loaded from Triton Connect, the machine can only be put into service by configuring the cassette multiple amount in Management Functions at the terminal. Subsequent update loads will not require this step.

---

## SUPPLEMENT E

---

### FULLY SUPPORTS TDM-2XX RETURN CODES

This release fully supports the TDM-2XX return codes. There are two classes of return codes where one is a soft error that the terminal will accept and retry the failed command. The second class is a fatal error and will cause the terminal to not retry and go out of service with the error code.

### TEST DISPENSE WITH TDM-2XX RETURN CODE INTACT

The TDM-2XX reports a status of the test dispense operation. This release corrects the reporting of that status information.

### TEST FOR TDM-1XXS BEFORE TDM-2XXS

This release corrects the problem of newer TDM firmware that responds to both command sets of the TDM product line. These command sets changes the way that cassettes are managed and error codes that are reported. This release will test for a single cassette TDM before testing for a TDM multi-cassette mechanism.

### AUTO RECOVERY FROM 139 PRINTER ERROR (9100 ONLY)

This maintenance release adds the capability to the terminal to auto-recover from an 139 error if possible. The 139 error condition indicates that the terminal experienced a problem with the printer. Previous releases required the Terminal Owner to restart the terminal and then reset the error. Now if the printer recovers from the error, the terminal will constantly test for this state and automatically reset the error and return into service. If paper was out when this error occurred, within 30 seconds of paper being reloaded, the terminal will go back in service.

### CRC VALIDATION REQUEST AND RESPONSE MESSAGES

This release adds the ability for the terminal to use a CRC to validate messages to/from the acquirers. If the host sends a 'ub' FID (described in the **CHANGES TO THE COMMUNICATION SPECIFICATION** section of this supplement), the terminal will validate the CRC instead of the LRC of the dial-up message. If the CRC validation fails, the terminal/acquirer shall follow the protocol for an invalid LRC.

### DEFAULT PASSWORD DETECTION

The terminal will no longer go into service if the Master and/or Administration passwords are configured in their default setting. A new error code (246) will be displayed when the passwords are in their default state. The terminal will detect this condition and go out of service. On the "Out of Service" screen, no error information will be displayed. The following are screen captures of this state. This error code will not clear until the Master and/or the Administration passwords are changed from their default state.

The default MASTER password is '123456' and the default ADMINISTRATION password is '987654'.

1. The following screen appears. Select MANAGEMENT option.



2. Enter the default MASTER password '123456'.

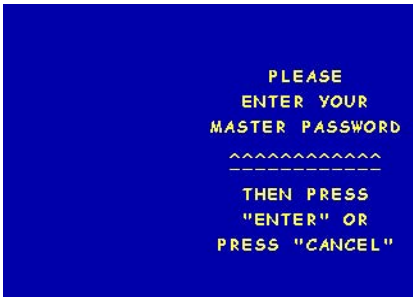

3. The following prompt appears. Select MANAGEMENT option.



4. The Main Menu appears. Select CONFIGURE TERMINAL (multi-host) or PASS-WORD MAINTENANCE.



5. Select PASSWORD MAINTENANCE.



6. Select **MASTER PASSWORD** option. Enter a new Master password.

**NOTE:** The terminal Master password consists of 4-12 digits (no characters).



7. Select **ADMINISTRATION PASSWORD** option. To view current Administration password, select **VIEW**.

To change the Administration password, select **CHANGE**. Enter a new Administration password.

**NOTE:** The Administration password consists of 4-12 digits (no characters).

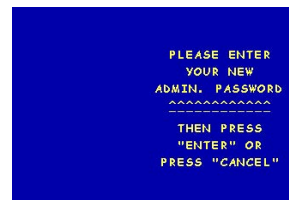
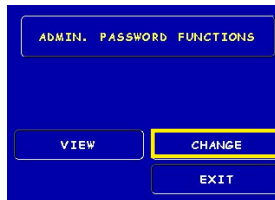
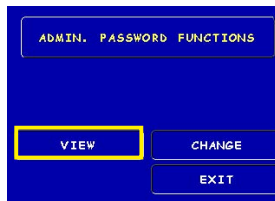

**\* NOTE \***

*If you use the same password for both the MASTER and ADMINISTRATION functions, the ATM defaults to the **MASTER** functions, the highest level options. **Never use the identical password for both MASTER and ADMINISTRATION!***

8. Exit out of Management Functions. The password(s) have been changed. Enter the new Master or Administration password to enter Management functions.

## CHANGES TO THE COMMUNICATION SPECIFICATION

The following changes have been made to Triton Standard Communications in order to support the new functionality of this release.

### Misc FID 'ub'

The following new FID will be utilized (as described in the Triton Terminal Communications Protocol and message Format Specification) to validate request and/or response messages. If the 'ub' FID is present in the response message to the terminal, the terminal will validate the CRC and not the LRC of the message when dial-up message protocol. The following describes the CRC calculation.

16-bit CRC.

4 ASCII characters that represent the CRC-16 two byte checksum.

Each character represents a 4-bit hexadecimal numeral (0-9, A-F).

Uses the ANSI CRC-16 error checking protocol standard.

For a request message the 16-bit CRC calculation starts with the first character after the STX, and ends with the last character before the ETX, includes four ASCII zeros for the 'ub' field, and excludes the LRC. The result is the four ASCII characters that is placed in the 'ub' field in msb to lsb order. The host must also calculate the CRC by substituting the four ASCII character CRC result in the 'ub' field with four ASCII zeros, then compare the results. The converse should be performed for the response message.

The Triton TCP/IP protocol does not contain an STX, ETX, nor LRC, and includes a two-byte TCP/IP message length in the CRC Calculation.

**SUPPLEMENT F**  
**(8100 / 9100 ATM)**  
**UK**  
**(MAR, 07)**

## NEW CHANGES

The following describes new changes implemented in the latest (Mar, 07) 8100/9100 UK software release with EMV support..

This supplement describes additional features/changes that make up this software. This software release also pertains to the Model 8100 terminal software, providing a single load file for updating 9100 or 8100 terminals.

1. TDM Support
2. Fully Supports TDM-2XX Return Codes
3. Test Dispense with TDM-2XX Return Code Intact
4. Test for TDM-1XXs before TDM-2XXs
5. Correcting the Screen Flow for the Printer Off-line Notification
6. Auto Recovery from 139 Printer Error (9100 only)
7. PIN Blocking being Cleared between EMV Transaction
8. Terminal Dispenses Cash after Remove Card Prompt
9. Upload Load Files can cause Long EMV Transaction Times
10. VISA AIDS
11. Configurable Delay to when Predial Starts
12. Default Password Detection

## TDM SUPPORT

The Triton 9100 ATM system supports a variety of TDM dispenser mechanisms (TDM-100/150, TDM-200/250 etc.) with this release. The approach has been to provide a common dispenser-resident firmware package for all TDM dispensers, making the terminal SW interface common to all types.

For the dual feed channel TDM-2XX dispensers, cassettes A through C are available for configuration. Cassette D is not supported for any of the TDM dispensers and should appear grayed out on all Management functions screens. The terminal immediately flags non-resident cassettes as “Out of Service” once the SW returns from Management functions to customer transactions for multi-feed channel mechanisms.

Single feed channel dispensers such as the TDM-50 for the 8100 and TDM-1XX dispensers for the 9100 display only cassette A, all other cassettes will appear grayed out. The cassette type has a default setting of ‘Cash’. They are automatically placed “In Service” after boot. The “In-Service” configuration and status items do not apply to single feed channel dispensers. Only the value parameter requires configuration after a full load. TDM-50 dispensers are single “fixed bin” dispensers (no actual cassette). The terms cassette and bin may be used interchangeably in the scope of this document.



**With this and future versions of 9100 software, when installing an update file over any prior software release on a terminal with a TDM50, TDM100, or TDM150 dispenser, the cassette multiple amount will need to be reconfigured before the terminal will go into service\*\*.**

**\*\*Note** - In this situation, if an update file is loaded from Triton Connect, the machine can only be put into service by configuring the cassette multiple amount in Management Functions at the terminal. Subsequent update loads will not require this step.

### **FULLY SUPPORTS TDM-2XX RETURN CODES**

This release fully supports the TDM-2XX return codes. There are two classes of return codes where one is a soft error that the terminal will accept and retry the failed command. The second class is a fatal error and will cause the terminal to not retry and go out of service with the error code.

### **TEST DISPENSE WITH TDM-2XX RETURN CODE INTACT**

The TDM-2XX reports a status of the test dispense operation. This release corrects the reporting of that status information.

### **TEST FOR TDM-1XXS BEFORE TDM-2XXS**

This release corrects the problem of newer TDM firmware that responds to both command sets of the TDM product line. These command sets changes the way that cassettes are managed and error codes that are reported. This release will test for a single cassette TDM before testing for a TDM multi-cassette mechanism.

### **CORRECTING THE SCREEN FLOW FOR THE PRINTER OFF-LINE NOTIFICATION**

The Printer off-line notification will now return the customer to the Transaction Cancelled screen then to the Welcome Screen when the No is selected or the screen exhausts its timeout waiting for input from the customer.

### **AUTO RECOVERY FROM 139 PRINTER ERROR (9100 ONLY)**

This maintenance release adds the capability to the terminal to auto-recover from an 139 error if possible. The 139 error condition indicates that the terminal experienced a problem with the printer. Previous releases required the Terminal Owner to restart the terminal and then reset the error. Now if the printer recovers from the error, the terminal will constantly test for this state and automatically reset the error and return into service. If paper was out when this error occurred, within 30 seconds of paper being reloaded, the terminal will go back in service.

### **PIN BLOCK NOT BEING CLEARED BETWEEN EMV TRANSACTIONS**

The PIN block is now cleared at that beginning of every Transaction including EMV transactions.

## MODEL 9100 USER MANUAL

---

### TERMINAL DISPENSES CASH AFTER REMOVE CARD PROMPT

At the end of an EMV Transaction, if the customer does not remove their card when prompted the terminal cancels the transaction and reverses the transaction with the host.

### UPDATE LOAD FILES CAN CAUSE LONG EMV TRANSACTION TIME

Update files contain a minimum set of default parameters. These files contain the parameter for the Card reader timeout during EMV data exchanges.

### VISA AIDs

Three new VISA AIDs were added to the terminal. They are as follows:

Visa Electron (AID: 0xA0000000032010)

Visa Interlink (AID: 0xA0000000033010)

Visa Plus (AID: 0xA0000000038010)

All VISA AIDs will be defaulted to disabled. This AIDs must be enabled through Management functions or Triton Connect.

### CONFIGURABLE DELAY TO WHEN PREDIAL STARTS

For locations with faster communication times, this release includes a parameter that adjust the time when predial starts. The predial delay is set to zero (0) which does not change any timing in both load files.

### DEFAULT PASSWORD DETECTION

The terminal will no longer go into service if the Master and/or Administration passwords are configured in their default setting. A new error code (246) will be displayed when the passwords are in their default state. The terminal will detect this condition and go out of service. On the “Out of Service” screen, no error information will be displayed. The following are screen captures of this state. This error code will not clear until the Master and/or the Administration passwords are changed from their default state.

The default MASTER password is '123456' and the default ADMINISTRATION password is '987654'.

1. The following screen appears. Select MANAGEMENT option.



2. Enter the default MASTER password '123456'.

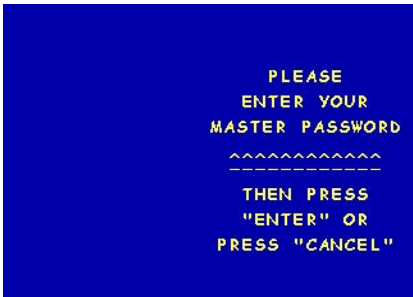

3. The following prompt appears. Select MANAGEMENT option.



4. The Main Menu appears. Select CONFIGURE TERMINAL (multi-host) or PASS-WORD MAINTENANCE.



5. Select PASSWORD MAINTENANCE.



6. Select **MASTER PASSWORD** option. Enter a new Master password.

**NOTE:** The terminal Master password consists of 4-12 digits (no characters).



7. Select **ADMINISTRATION PASSWORD** option. To view current Administration password, select **VIEW**.

To change the Administration password, select **CHANGE**. Enter a new Administration password.

**NOTE:** The Administration password consists of 4-12 digits (no characters).

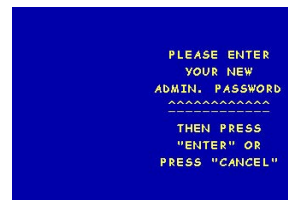
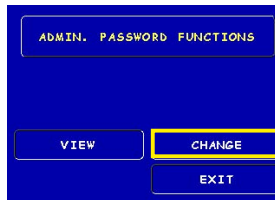
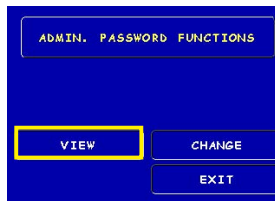

Guide Courtesy of

**\* NOTE \***

*If you use the same password for both the MASTER and ADMINISTRATION functions, the ATM defaults to the **MASTER** functions, the highest level options. **Never use the identical password for both MASTER and ADMINISTRATION!***

8. Exit out of Management Functions. The password(s) have been changed. Enter the new Master or Administration password to enter Management functions.