

# ATMDEPOT.COM

MORE MONEY IN YOUR POCKET

## OWNER'S MANUAL

# Triton RL1600



# ATMDEPOT.COM

MORE MONEY IN YOUR POCKET



CAN WE SHOW YOU HOW TO  
MAKE MORE MONEY FROM  
YOUR ATM MACHINE?

**WORLD CLASS EQUIPMENT & PROCESSING  
PLUS BUSINESS & TECHNICAL SUPPORT**

**ATM  
BUSINESS**

**ATM  
PROCESSING**

**ATM  
EQUIPMENT**

**Net More  
Money**



**Call 888-959-2269**

**ASK ABOUT FREE  
CUSTOM WELCOME SCREEN GRAPHICS  
& PRESS RELEASES FOR OUR CLIENTS**

## NOTICES

Copyright © Delaware Capital Formation, Inc., 2007-2008.

### ALL RIGHTS RESERVED

This publication is protected by copyright and all rights are reserved. No part of it may be reproduced or transmitted by any means or in any form, without prior consent in writing from Triton Systems of Delaware, Inc.

The information in this publication has been carefully checked and is believed to be accurate. However, Triton Systems of Delaware, Inc. assumes no responsibility for any inaccuracies, errors, or omissions that may be contained in this document. In no event will Triton Systems of Delaware, Inc. be liable for direct, indirect, special, incidental, or consequential damages resulting from any defect or omission in this manual, even if advised of the possibility of such damages.

In the interest of continued product development, Triton Systems of Delaware, Inc. reserves the right to make improvements in its documentation and the products it describes at any time, without notice or obligation.

### TRADEMARK ACKNOWLEDGEMENTS

Microsoft Windows is a registered trademark of Microsoft Corporation in the United States and/or other countries. Triton Connect is a trademark of Triton Systems of Delaware, Inc. VISA® is a registered trademark of VISA of the United States and other countries.

CONTENTS

**SECTION 1 - INTRODUCTION .....1**  
WHAT'S IN THIS MANUAL.....2  
FEATURE HIGHLIGHTS / CHANGES.....3-4  
STANDARD FEATURES .....4-5

**SECTION 2 - BASIC OPERATION .....7**  
INTRODUCTION .....8  
CONTROL PANEL LAYOUT.....8  
FUNCTION KEYPADS .....9  
MAIN KEYPAD .....9  
ON-SCREEN KEYPAD OPERATION.....10  
MENU-BASED OPERATION .....11  
CUSTOMER TRANSACTIONS.....12  
VOICE-ENABLED TRANSACTIONS .....14

**SECTION 3 - CASSETTE CLOSE / CASH REPLENISHMENT.....15**  
INTRODUCTION .....16  
DISPENSING MECHANISMS.....16  
NOTE CONDITION .....17  
PREPARING NOTES.....17  
**CASSETTE CLOSE PROCEDURES.....18**  
**REPLENISH CASSETTE(S).....19**  
MINIMECH.....19-20

**SECTION 4 - GENERAL MAINTENANCE.....21**  
INTRODUCTION .....22  
REPLENISHING THE RECEIPT PAPER.....22-24  
CLEANING THE ENCLOSURE.....25  
CLEANING THE DISPLAY.....25  
CARD READER CLEANING .....25

CONTENTS

**APPENDIX A - SOFTWARE LICENSE AGREEMENT .....A-1**

**APPENDIX B - WARRANTY STATEMENT .....B-1**

**APPENDIX C - ELECTRONIC LOCKS.....C-1**

**APPENDIX D - MECHANICAL LOCKS.....D-1**

**SUPPLEMENT A - T5 AND T7 EPP BATTERY REPLACEMENT PROCEDURES.....SA-1**

**SUPPLEMENT B - KEY MANAGEMENT.....SB-1**

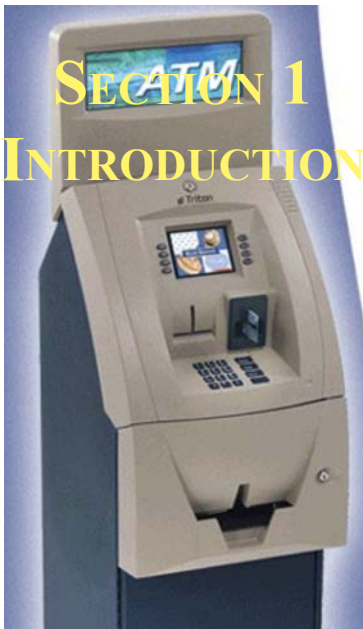

## WHAT'S IN THIS MANUAL

The User manual describes the operating features of the Model RL1600 series ATM and shows how to perform the procedures that would typically be performed by the owner or operator personnel.

The manual is divided into the following sections:

**SECTION 1, INTRODUCTION.** Summarizes the basic features of the Model RL1600 series ATM.

**SECTION 2, BASIC OPERATION.** Describes the basic operation of the terminal:

- Control Panel Layout.
- Keypads (Function, Main, On-Screen)
- Menu-Based Operation
- Customer Transaction Process
- Voice-Enabled Transactions

**SECTION 3, CASSETTE CLOSE / CASH REPLENISHMENT.** Describes the menu functions for cassette close procedures. Cash replenishment steps for each dispenser and standards are covered as well.

**SECTION 4, GENERAL MAINTENANCE.** Describes normal preventative and corrective maintenance procedures appropriate for user personnel.

- Replenishing Receipt Paper
- Cleaning the Enclosure/Card Reader

**APPENDIX A - SOFTWARE LICENSE AGREEMENT / COMPLIANCE STATEMENTS**

**APPENDIX B - WARRANTY STATEMENT**

**APPENDIX C - ELECTRONIC COMBINATION LOCKS**

**APPENDIX D - MECHANICAL COMBINATION LOCKS**

**SUPPLEMENT A - T5 AND T7 BATTERY REPLACEMENT PROCEDURES**

**IMPORTANT: Follow the instructions provided in SUPPLEMENT A of this manual for replacing the battery for either the T5 or T7 PCI-EPP. Failure to follow the explicit instructions for the T5 will permanently damage the keypad!**

**SUPPLEMENT B - T5-T7 KEY MANAGEMENT FUNCTIONS.**

### FEATURE HIGHLIGHTS

Important features of the RL1600 series ATM are highlighted in the following list:

- Highly reliable, state-of-the-art operating system PC platform design. The RL1600 uses Microsoft® Windows® CE.5.0 operating system with Triton's X2 technology. Supports Windows file formats for adding custom logos and advertisements. In addition, it features Triton's completely custom design X2 motherboard with integrated modem.
- Modular architecture eases troubleshooting and servicing.
- Front-access unit accommodates single cassette (MiniMech,)
  - Only one cabinet design, shallow, accommodates the dispenser mechanism offered.
  - Cabinet available in UL 291 Business Hours only. **Cash must be removed after hours.**
- 5.7" (145mm) color LCD display.
- T7 PCI-compliant EPP to comply with international encryption standards and Triple DES compliant.



## FEATURE HIGHLIGHTS

- ❑ Easy to install (small footprint design makes placement easier) and configure terminal parameters by software.
- ❑ Supports communication types TCP/IP (standard), dial-up (56K baud Triton USB modem - integrated on motherboard): VSAT (satellite), Radio Pad, and wireless optional.  
*(Note: For wireless option, please contact your account representative for more information).*
- ❑ Multi-function, dip-style card reader supports magnetic stripe cards or “smart” cards that conform to the EMV standard. (215 Standard DIP [US] or IS65 EMV DIP [Canada ONLY])
- ❑ Graphics-capable 60 mm gravity-fed thermal printer designed for quiet operation. Prints receipts, coupons, and management reports.
- ❑ Mechanical (standard) or electronic combination lock (optional, field installed).
- ❑ Supports remote setup, configuration, and monitoring via Triton Connect™ ATM monitoring software.
- ❑ Dispenses U.S. and international currency types.
- ❑ High-capacity electronic journal stores transaction details for later printout and analysis.
- ❑ Satisfies Americans with Disabilities Act (ADA) specifications for height and access; audio transactions for the visually impaired. Complies with UK accessibility guidelines (DDA) and California access compliance, Title 24.
- ❑ LED-backlit signage standard (Mid topper attachment).
- ❑ Bayou Bronze control panel and fascia color.

## STANDARD FEATURES

- ❑ **MANAGEMENT FUNCTIONS.** Enable extensive control and customization of the ATM’s operating parameters. See “**X-SCALE/X2 CONFIGURATION MANUAL**” on web site.
- ❑ **PASSWORD PROTECTION.** Access to Management Functions and Key Management areas are protected with passwords.
- ❑ **MAC ENCRYPTION SUPPORT.** Message Authentication Code (MAC) data encryption protocol. Provides increased protection for message traffic to and from the ATM. *Triple DES compliant.*
- ❑ **PCI-COMPLIANT ENCRYPTING PIN PAD (EPP) ENTRY DEVICE SUPPORT.** Secure EPP device encrypts the customer PIN during a transaction. *Triple DES and PCI compliant.*
- ❑ **MULTI-LANGUAGE SUPPORT.** Enables the customer to select a preferred language (such as French or Spanish) for customer screens and receipts.

## INTRODUCTION

---

- ❑ **TRANSACTION AND ACCOUNT TYPE CONFIGURATION.** Enables selection of transactions (transfers or balance inquiries) or accounts (savings or credit card) that will be presented to the customer. Does not affect availability of checking account withdrawal.
- ❑ **CASSETTE AND DAY CLOSE REPORTS.** Provide summary information about the number and type of transactions being performed by the ATM.
- ❑ **ELECTRONIC JOURNAL.** Stores the details of each transaction in solid-state memory. Journal data can be retrieved, printed, saved to an external storage device, or transferred to a remote Triton Connect™ computer.
- ❑ **AD SCREENS.** An Ad screen is a promotional or advertising graphic that is displayed on the LCD screen during idle periods. Ad screens are downloaded to the terminal by either using an external storage device (jumpdrive) or a remote Triton Connect™ computer. Text-only (non-graphic) ad screens can also be displayed.
- ❑ **RECEIPT PRINTER GRAPHICS.** This feature allows informational or promotional graphics to be printed on customer receipts. Graphics can be loaded from an external storage device or Triton Connect™.
- ❑ **MESSAGES.** Informational and promotional messages that are displayed to the customer on-screen or printed on receipts.
- ❑ **COUPONS.** Coupons can be printed by the receipt printer. Prizes may be awarded to customers based on random and/or withdrawal amount-based transactions. Coupon text can be entered locally or downloaded along with coupon graphics using Triton Connect™ software.
- ❑ **STATUS MONITORING.** The ATM can periodically transfer status information to the host processor. In addition, Triton Connect™ remote monitoring software can be used to view the journal, monitor operation and alarm conditions, update operating parameters, and reset the terminal.
- ❑ **UL 291 BUSINESS HOURS SERVICE.** Business hours cabinet means currency should be removed from the dispenser and stored in a safe location when the business is closed to the public.
- ❑ **FRONT-ACCESS CABINET.** Allows access to the dispensing mechanism and currency cassette from the control-panel side of the unit.

Weight of the RL1600 (Approximate)	
Business Hours	Configuration
140 lbs 63 Kilos	Shallow cab MiniMech mid topper

**SECTION 2**  
**BASIC OPERATION**

## INTRODUCTION

This section describes the basic operation of the terminal. The following topics are covered:

1. **CONTROL PANEL LAYOUT.** Describes the layout of the terminal's control panel.
2. **KEYPAD OPERATION.** Describes the use of the alphanumeric keypads.
3. **MENU-BASED OPERATION.** Gives a general overview of the terminal display interface.
4. **CUSTOMER TRANSACTIONS.** Summarizes the actions involved in typical customer transactions. In addition, the voice-enabled transactions feature is described.

## CONTROL PANEL LAYOUT

The user interface of the terminal consists of the LCD screen, receipt chute, card reader, speaker, headphone jack (visually impaired), and 24 keys on three keypads. The Function keys are arranged in two four-key groups, one group on either side of the LCD display. The main keypad consists of 10 alphanumeric keys, two arrow keys and four large control keys, all located in a 16-key group beneath the LCD screen.

The main keypad and control keys have an integral raised Braille symbol to conform to the requirements of the Americans with Disabilities Act (Figure 2-1).



Figure 2-1. Control panel layout.

FUNCTION KEYS

The eight (8) keys, arranged in two four-key groups, are called screen function keys. A screen function key is only active when a corresponding function or menu option is present next to that key. The Function keys are designated F1 through F8, as shown in Figure 2-2.

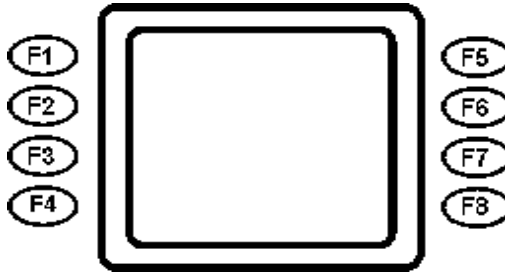

Figure 2-2. Function key layout.

MAIN KEYPAD

The entry of numeric characters via the main keypad is straightforward: simply press the desired key. However, in certain Management Function screens it may be necessary to enter alphabetic characters, a procedure that's available with the On-Screen keypad, explained on next page.

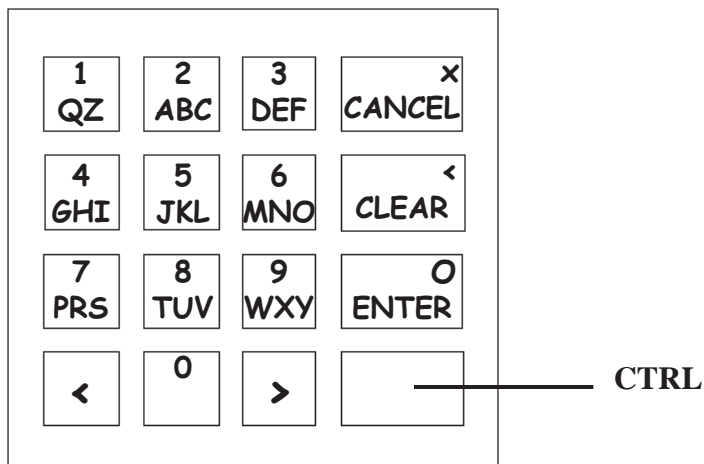

Figure 2-3.  
Alphanumeric  
keypad.

**ON-SCREEN KEYPAD OPERATION**

To enter text characters into the dialog boxes that are displayed by the Management Functions, press the **F8** key to display the screen keyboard. Use the keys described below to navigate and enter required data. (see Figure 2-4)

- The Arrow keys (< and >), the <8> key - (**UP**), and the <0> key - (**DOWN**) navigate the keyboard.
- Press the <ENTER> key to select the highlighted key entry.
- Press the <CTRL> key to switch between upper and lower case characters.
- Press the <CANCEL> key to Exit the keyboard.
- Press the <CLEAR> key for the Backspace operation.
- Press the <1> key to reposition the keyboard to another location on the display.
- Press the <2> key to position the cursor on a new line.

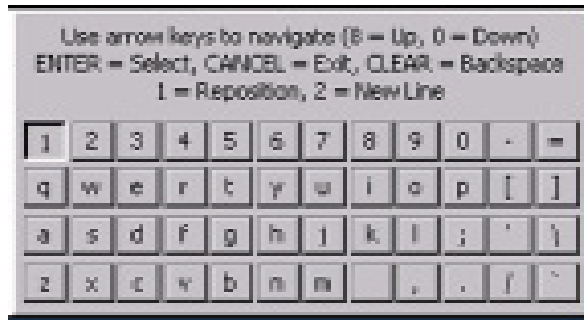

Figure 2-4. On-screen keyboard.

### MENU-BASED OPERATION

The terminal operates as a menu driven system. Messages and menu options presented on the LCD display screen guide the user's actions. The desired menu option is selected by pressing one of the keys located to the left and right of the display. For the purpose of security many screens timeout after a preset time interval, usually 30 seconds. The timeout length may vary depending on the function being performed.

When a screen timeout occurs, a screen is presented which asks the user if more time is needed. If the user chooses NO, the Customer Welcome screen will be presented. If YES is chosen, the user is returned to the function that was active prior to the timeout. If the user does not make a selection within an additional 30-second countdown period the terminal will automatically go to the Customer Welcome screen.

Ensure all procedures in the Installation Guide have been accomplished. The unit should be off, with the power cord and communications cable connected. Power on the unit by placing the power switch on the power supply to the on position. Shortly after the unit is turned on, the top menu will be displayed. An example top menu is shown in Figure 2-5. From the top menu, you can either:

1. Activate the terminal to perform customer transactions by pressing the key next to **CUSTOMER TRANSACTIONS**.
  2. Enter the terminal system management area by pressing the key next to **MANAGEMENT FUNCTIONS**.
- Note:** *You will have to enter an appropriate password to view the Management Functions menu.*

If you do not select a menu choice within 30 seconds the terminal will automatically default to the Customer Welcome screen (a benefit of this feature is that in the event of a power interruption the terminal will automatically begin accepting customer transactions shortly after power is restored).



Figure 2-5. Top menu screen.

CUSTOMER TRANSACTIONS

A customer begins a transaction by selecting from the Customer screen options. They insert their ATM card into the card reader of the terminal. The card must be inserted so that the magnetic stripe can be scanned by the card reader's sensor. If the customer inserts the card incorrectly, a warning message will be displayed, accompanied by several beeps to get their attention.

If there is a problem reading a card, make sure the customer is inserting the card correctly. Most problems are the result of inserting the card incorrectly.

Once the card has been read in successfully, a surcharge message, if applicable, may be displayed (the surcharge message may be displayed at the end of the customer's transaction selection). The customer must then enter their secret Personal Identification Number (PIN) code. Once the PIN has been entered, the transaction type and account are selected, and the desired amount of the transaction, if needed. The transaction will be processed, typically in a matter of seconds.

Figure 2-6 shows how ATM transactions are handled. If the transaction was processed successfully, the customer is prompted to retrieve the requested cash (for withdrawal transactions) and/or the applicable transaction receipt, as needed. If the transaction was declined, a short receipt indicating the problem is printed.

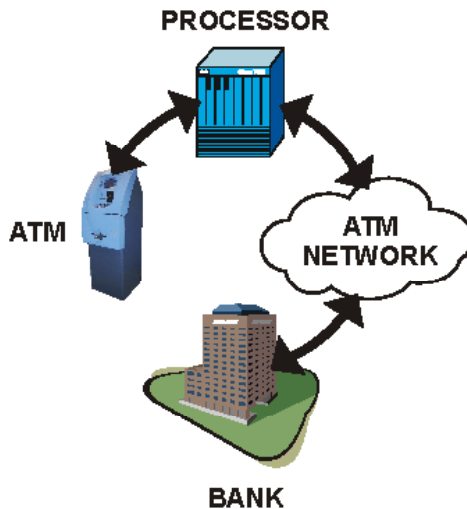

Figure 2-6. ATM transaction processing.



The ATM sends the customer transaction request to a processor. A processor is a financial intermediary, such as an Independent Sales Organization (ISO), bank, or other financial institution that provides transaction-processing services for ATMs. The ATM must be set up with a particular processor before customer transactions can take place.

The processor routes the transaction to the appropriate ATM network. An ATM network is a regionally or nationally organized clearing house for financial transactions, that deals directly with the appropriate financial institution, such as the customer's bank or credit card company, in order to complete the transaction. The processor will select the appropriate ATM network to use based on factors such as the type of ATM or credit card used, location of the customer's bank, or other considerations. The transaction may be transferred between several networks before ultimately reaching the customer's bank or credit card company.

The ATM network routes the transaction to the appropriate bank or other institution, confirms successful completion of the transaction, and sends a confirmation message back to the processor. If the request was for a cash withdrawal, an Electronic Funds Transfer (EFT) takes place to debit the funds (including any surcharge fee, if applicable) from the customer's bank account and credit the funds to the processor's bank account.

The processor forwards a confirmation message to the ATM (and an authorization to dispense currency, in the case of a cash withdrawal). The ATM dispenses the requested currency, if necessary, and provides the customer with a printed receipt as a record of the transaction.

The processor credits the merchant's account for the amount of any cash withdrawals (plus surcharge fees, if collected), typically by the end of the next business day).

### VOICE-ENABLED TRANSACTION

The terminal provides voice feedback via an integrated output jack, enabling sight-impaired users to plug in a set of headphones and receive spoken instructions to assist them in using the ATM (Figure 2-7).

A raised symbol helps a user locate the headphone jack. The ATM will automatically detect when a headphone has been plugged into the jack, and will immediately switch into voice mode. Initially, a brief spoken tutorial will orientate the customer to the ATM control panel interface. Once the customer begins a transaction, spoken prompts will provide feedback and guide the customer through the successful accomplishment of the transaction.



*Figure 2-7. Headphone jack location.  
(Typical)*



**SECTION 3**

**CASSETTE CLOSE**

**CASH REPLENISHMENT**

**INTRODUCTION**

The purpose of this section of the manual is to describe the procedures for cassette closing and replenishment. Information concerning note handling and quality issues are explained where appropriate.

**DISPENSING MECHANISMS**

**\* PLEASE READ \***

The Model RL1600 production units are equipped with the MiniMech dispenser.

Also, there will only be one style of cabinet offered which can accommodate the dispenser mentioned above.

Currency capacity depends upon the dispenser mechanism installed in the ATM, but is also affected by note quality and thickness. Typical capacities are provided in the following table: **DO NOT** be tempted to over fill the cassette.

<b>RL1600 DISPENSING MECHANISM</b>			
<b>DISPENSER</b>	<b>CASSETTE</b>	<b>RECOMMENDED MAXIMUM CAPACITY</b>	<b>REJECTED NOTE CAPACITY</b>
<b>Minimech</b>	<b>Single</b>	<b>750 Notes</b>	<b>Less than 100</b>

The dispensing mechanism delivers the appropriate number of notes from the note cassette to fulfill the customer's withdrawal request. The purpose of the reject area or cassette is to accept and hold notes that have been transferred from the note cassette but not dispensed. Some situations that could cause the mechanism to reject notes are:

- (1) Multiple notes stuck together
- (2) Note width too short or long.

Other conditions that could cause a reject are described in the next section, Note Condition.

**\*\*CAUTION\*\***  
**DO NOT RECYCLE REJECTED NOTES INTO A CASSETTE!**  
**Doing so could cause more rejects and/or currency jams.**

### NOTE CONDITION

The number of rejects can be directly influenced by the technique used to load the cassettes and the quality of the currency. Notes loaded into the mechanism cassettes must be in “fit” condition if a high level of performance (low reject and failure rate) is expected from the unit. “Fit” notes are defined as those that do not possess any of the defects listed here:

### USED NOTE DEFECTS

- Adhesive or “sticky” substances on the surface of the paper.
- Tears extending more than 1/2” from the edge of the currency.
- Tears, holes, or missing sections in the body of the currency.
- Tape on the surface of the currency used for repairing, patching or any other purpose.
- Staples, pins, or any other foreign body attached to the notes.
- Corner folds of a size greater than 1/2” on either axis.
- Two or more notes joined by any means.
- Excessively crumpled or crinkled.

### PREPARING NOTES

Use the following procedures to prepare notes before inserting them into a note cassette.

#### PREPARING USED NOTES

- Remove the band around each bundle of notes.
- Remove foreign objects (e.g. pins, paper clips, crumbs, etc.).
- Remove torn or very worn notes.
- Straighten any folded notes.

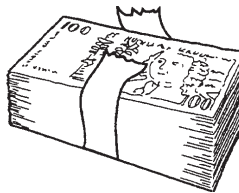

Figure 3-1. Removing band.

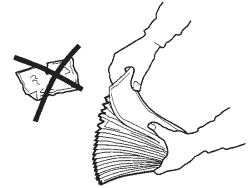

Figure 3-2. Removing torn/worn notes.

#### NEW OR UNCIRCULATED NOTES

Remove the band around each bundle of notes. Separate the notes from each other by:

- **Striking** the bundle hard against the edge of a table or similar object.
- **Flipping** through each bundle of notes in both directions at each end.
- Using a **note counter**.

CASSETTE CLOSE PROCEDURES

Follow Access instructions to enter **MANAGEMENT FUNCTIONS**. Select **TERMINAL CLOSE FUNCTIONS**. Select **CASSETTE CLOSE**.

- 1 Select cassette(s) to Close. A check mark (✓) identifies which cassette(s) are selected. Press <Enter>.
- 4 After cassette(s) have been reinserted in the dispenser, press <Enter>.

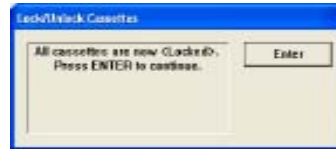

- 2 A Close report is displayed to be printed or saved. This operation will reset the number of bills in the cassette(s) to ZERO (0). Press <Enter>.

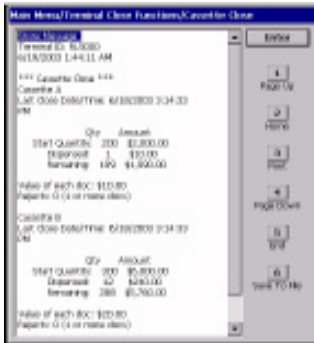

- 5 Place selected cassette(s) **IN SERVICE**. Press <Enter>.



- 3 Remove and Replenish the selected cassette(s).

**Procedures for cassette replenishment are on the following pages.**



- 6 Enter Cassette Quantity (number of notes, NOT value) for the selected cassette(s). Press <Enter> to accept entry. Repeat for each selected cassette.

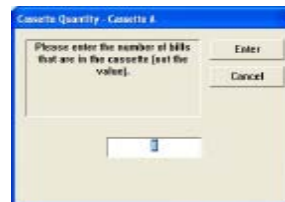

- 7 A Trial Cassette Close report automatically is displayed to be printed or saved. Print and retain a copy for starting point reference. Press <Enter> to return to Close functions.

Replenish Cassette  
Mech 10 (MiniMech)

1. Unlock and open the security cabinet door.
2. To remove the note tray, grasp the tray handle and slide the tray out of the mechanism. Place note tray on a flat level surface.
3. Remove any rejected notes. The reject compartment is located nearest the handle side of the tray.

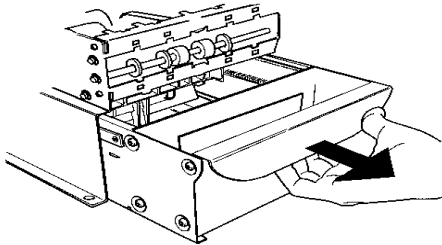

*Removing note tray from the dispensing mechanism.*

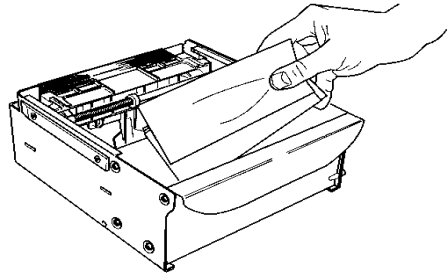

*Removing rejected notes.*

**Note:** You may wish to record the number of notes removed from the reject compartment for use when balancing the note tray against the cassette/day close records.

**Loading the Note Tray**

1. Move the pusher plate to the rear of the tray (toward the handle). Ensure the pusher plate is fully back. Maintain pressure on the pusher plate as needed while loading notes.
2. Count the number of bills that remain in the cassette, if any. Next, count the number of bills that are being added into the cassette.
3. Add the number of bills being placed into the cassette to the number that remained. The “Total” number of these bills will be entered in the “Enter Cassette Quantity” option.

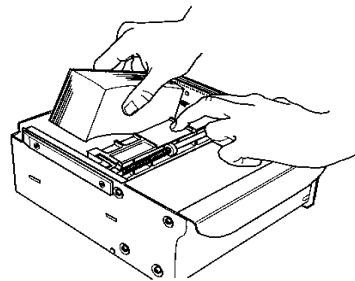

*Load note tray with currency.*

4. Place the currency into the cassette. Allow at least one inch of clearance between the packer plate when it is fully retracted and the currency. This will allow the packer plate to compress the currency.
5. Release the pusher plate against the notes.
6. Using the handle, slide the note tray into the dispensing mechanism. Make sure the note tray is fully inserted!

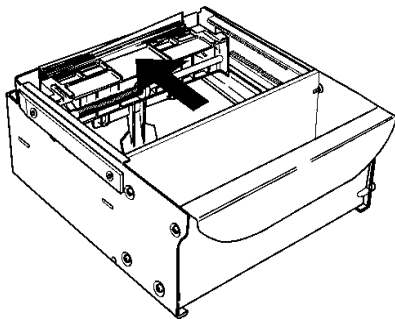

*Release pusher plate*

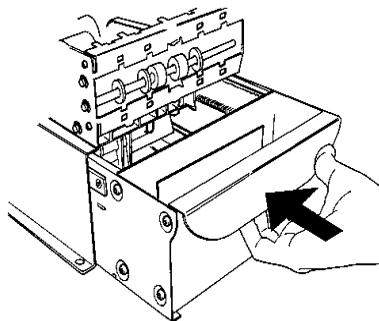

*Slide note tray into dispenser mechanism.*

7. Close and lock the security container.



**SECTION 4**  
**GENERAL MAINTENANCE**

## INTRODUCTION

This section of the manual covers preventive and corrective maintenance procedures appropriate for user personnel. The following areas are covered:

1. **REPLENISHING RECEIPT PAPER.** Describes how to replace a spent receipt paper roll.
2. **CLEANING THE ENCLOSURE.** The proper way to clean the ATM housing.
3. **CARD READER CLEANING.** The recommended card reader cleaning technique.

### **\*Important\***

**Only qualified service personnel are authorized to repair or service the terminal. Should a malfunction occur, DO NOT attempt to service the unit yourself! Contact your Triton certified service provider!**

## REPLENISHING THE RECEIPT PAPER

***NOTE: This operation must be completed with the AC power applied to the ATM.***

1. Open the control panel by unlocking the top enclosure and pulling the hinged door forward.
2. If paper remains on the roll, cut or tear the paper between the roll and the printer.

### **\*\* Caution \*\***

**DO NOT pull receipt paper backwards through the printer! This may leave paper fragments that can cause paper jams.**

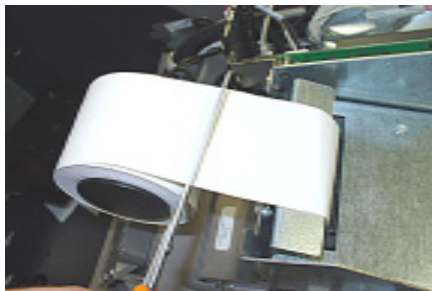

*Cut paper between the roll and printer feed path.*

3. Use the receipt printer feed button to feed the paper through the paper path until all paper comes out the front of the printer.
4. Remove the paper and spool from the paper bracket.



*Paper feed button location.*

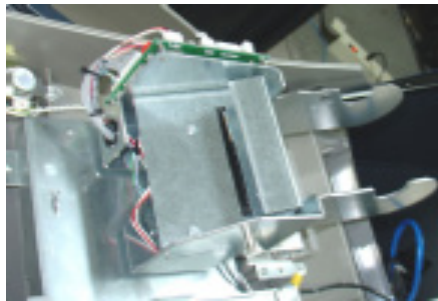

*Remove paper roll from bracket.*

5. Remove the tab securing the end of the new paper roll to itself. Use scissors to cut off all of the paper up to and including the glue tab.

Remove the plastic spindle from the old paper roll and insert into the new roll of paper. Use a 4-inch roll of 60 mm wide thermal paper, printer applicable.

Be sure the spindle is inserted so that the paper will feed from the **TOP** of the roll when it is installed on the paper bracket.

6. Place the new roll back on the paper bracket by sliding the small, slotted end of the spindle onto the slot in the bracket as shown. **Note that the paper feeds from the TOP of the roll!**

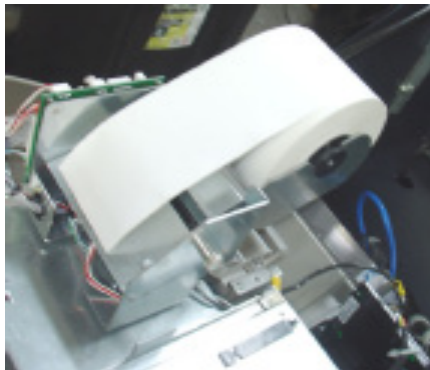

*Place paper roll on bracket. Paper feeds from top of roll!*

7. Feed the end of the paper into the printer take-up slot. The printer will activate and automatically feed the paper through the printer and slightly out the front of the control panel.
8. If the printer does not feed automatically, open the printer assembly by pulling the release pin on the side.

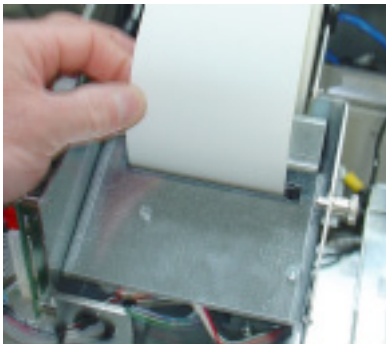

*Feed paper into the printer take-up slot.*

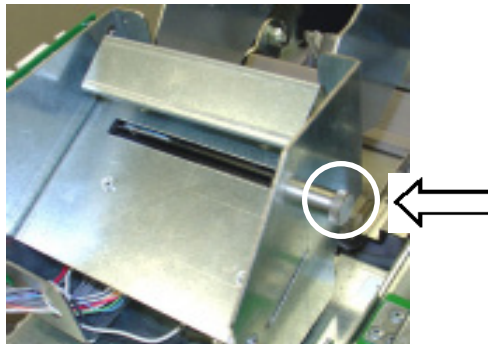

*Release pin location.*

9. Rotate the printer towards the front of the unit.
10. Check the blue lever to ensure it's in the correct position as shown. If it is not in the position shown, move the lever (moves in 3 positions) to the correct position. Close the printer assembly and perform step 7 again. Ensure the printer is secured by the release pin.

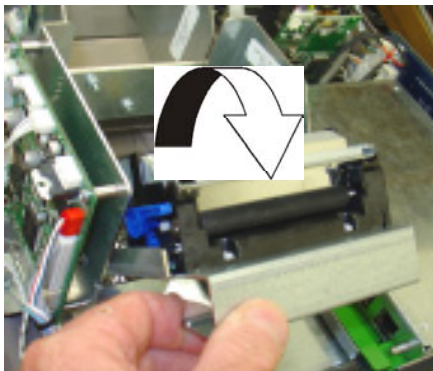

*Rotate printer open.*



*Blue tension lever (correct position).*

11. Close and lock the control panel. Go to **MANAGEMENT FUNCTIONS > DIAGNOSTICS** and perform a **RESET/TEST PRINTER**.

### CLEANING THE ENCLOSURE

The ATM front panel is highly durable, resisting scratches and finger smudges. However, occasional cleaning of the front panel and the plastic enclosure may be desirable. A soft dry or slightly damp cloth may be used for cleaning. For best results, use a weak solution of a mild detergent and water.

**\*\* Caution \*\***

**Avoid using abrasive cleaners on any surface of the terminal.  
Do not spray liquid cleaner directly on the unit, inside or out.**

### CLEANING THE DISPLAY

The Liquid Crystal Display (LCD) on the front of the ATM has a plastic protective window that should be cleaned only with a soft cloth, dampened with a weak solution of a mild detergent and water.

**\*\* Caution \*\***

**Do not use any abrasive cleaners on the window as it will scratch. Do not spray liquids onto the screen as they may run down inside the unit and cause damage.**

### CARD READER CLEANING

Special cleaning cards (P/N 06200-00055) are available for proper maintenance of the card reader. The reader should be cleaned at least once a month by inserting and removing a cleaning card, as shown below. It may be necessary to clean the card reader more often in locations that see heavy usage.

1. Remove the cleaning card from the sealed pouch.
2. Insert the cleaning card into the card reader and move in and out several times.
3. Remove the cleaning card and turn over to use other side.
4. Insert again several times.
5. Remove cleaning card and discard. They are designed to be used only once.

**APPENDIX A**  
**SOFTWARE LICENSE AGREEMENT**  
**COMPLIANCE / EMISSION STATEMENTS**

---

**AUTOMATED TELLER MACHINE (“ATM”) SOFTWARE  
END-USER AGREEMENT**

**IMPORTANT: PLEASE READ CAREFULLY:**

BY INSTALLING OR OTHERWISE USING THE ATM, YOU (AS THE OWNER OR LESSEE OF THE ATM), AGREE TO BE BOUND BY THE FOLLOWING TERMS AND CONDITIONS, INCLUDING, WITHOUT LIMITATION, THE WARRANTY DISCLAIMERS, LIMITATIONS OF LIABILITY AND TERMINATION PROVISION WHICH APPLY TO YOUR USE OF THE ATM SOFTWARE CONTAINED IN THIS ATM AND IS HEREBY LICENSED BY TRITON SYSTEMS OF DELAWARE, INC. (“Triton”) TO YOU PURSUANT TO THIS AGREEMENT.

IF YOU DO NOT AGREE TO OR ARE NOT WILLING TO BE BOUND BY THE TERMS AND CONDITIONS OF THIS AGREEMENT, DO NOT INSTALL OR OTHERWISE USE THIS ATM AND PROMPTLY CONTACT YOUR VENDOR. INSTALLING OR OTHERWISE USING THE ATM INDICATES THAT YOU ACCEPT THESE TERMS.

This ATM is manufactured by, and utilizes proprietary software owned by Triton Systems of Delaware, Inc. and/or its suppliers. All right, title and interest in and to all component software installed or embedded in the ATM (“ATM Software”) including all associated intellectual property rights, are and will remain the property of Triton and/or its suppliers.

**LICENSE:** Triton grants you a limited, nonexclusive license to use the ATM Software but only in connection with the operation of this ATM subject to the terms and restrictions set forth in this License Agreement. You are not permitted to use the ATM Software in any manner not expressly authorized by this License. You acknowledge and agree that ownership of the ATM Software and all subsequent copies thereof regardless of the form or media are held by Triton or its suppliers.

The software is licensed for use on this specific Triton ATM product and may not be used on any other product. Otherwise, the supporting documentation, if any, may be copied only as essential for backup or archive purposes in support of your use of the ATM. You must reproduce and include all copyright notices and any other proprietary rights notices appearing on any copies that you make.

**ASSIGNMENT: NO REVERSE ENGINEERING:** You may transfer the ATM Software to another party but only in connection with a transfer of all your right, title and interest in and to this ATM and if such party accepts the terms and conditions of this License Agreement. If you transfer the ATM, you must at the same time transfer the supporting documentation, if any, to the same party or destroy any such materials not transferred. Modification, reverse engineering, reverse compiling, or disassembly of the ATM and/or the ATM Software is expressly prohibited.

## DISCLAIMER OF WARRANTIES AND LIMITATION OF DAMAGES

TO THE EXTENT PERMITTED BY LAW, THIS ATM SOFTWARE, INCLUDING ALL INCORPORATED THIRD PARTY SOFTWARE, AND DERIVATIVES IS PROVIDED, "AS IS". TRITON MAKES NO REPRESENTATIONS WITH RESPECT TO, AND DOES NOT WARRANT THE PERFORMANCE OR RESULTS YOU OR YOUR CUSTOMERS MAY OBTAIN BY USING THE ATM. TRITON SPECIFICALLY DISCLAIMS ANY AND ALL WARRANTIES, EXPRESS, IMPLIED OR STATUTORY, INCLUDING WITHOUT LIMITATION, WARRANTIES OF QUALITY, PERFORMANCE, NONINFRINGEMENT, AND MERCHANTABILITY OR FITNESS FOR ANY PARTICULAR PURPOSE.

TRITON MAKES NO REPRESENTATIONS OR WARRANTIES AND ASSUMES NO OBLIGATIONS TO YOU OR YOUR CUSTOMERS WITH RESPECT TO ANY TRANSACTION OR SERVICES ACCESSED AND/OR UTILIZED IN CONSUMER-INITIATED TRANSACTIONS MADE FROM THIS ATM. IN NO EVENT WILL TRITON, ITS AFFILIATES, DIRECTORS, OFFICERS, EMPLOYEES, AGENTS OR SUPPLIERS BE LIABLE TO YOU UNDER ANY THEORY OF TORT, CONTRACT, STRICT LIABILITY OR OTHER LEGAL OR EQUITABLE THEORY FOR ANY PUNITIVE, CONSEQUENTIAL, INCIDENTAL, SPECIAL OR SIMILAR DAMAGES, INCLUDING ANY LOSS PROFITS OR LOST SAVINGS, EVEN IF A TRITON AGENT OR REPRESENTATIVE HAS BEEN ADVISED OF THE POSSIBILITY OF SUCH DAMAGES, OR FOR ANY CLAIM BY ANY THIRD PARTY.

YOUR SOLE REMEDY AGAINST TRITON FOR DEFECTIVE PERFORMANCE OF THE ATM SOFTWARE WILL BE LIMITED EXCLUSIVELY TO REPAIR OR REPLACEMENT OF THE ATM AND/OR THE ATM SOFTWARE, AT TRITON'S SOLE DISCRETION.

Any warranty pertaining to the ATM, its mechanical components exclusive of the ATM software, shall be governed and controlled by any warranty given to you by Triton in a separate document accompanying this ATM.

The foregoing limitation of liability and exclusion of certain damages will apply regardless of the success or effectiveness of other remedies.

**GOVERNING LAW:** This License Agreement shall be governed by the laws of the State of Mississippi and by the laws of the United States, excluding their conflicts of laws principles.

**SEVERABILITY:** In the event any provision of this License Agreement is found to be invalid, illegal or unenforceable, the validity, legality and enforceability of any of the remaining provisions shall not in any way be affected or impaired.

**ENTIRE AGREEMENT:** This License Agreement and the accompanying Limited Warranty set forth the entire agreement between you and Triton, supersedes all prior agreements, whether written or oral, with respect to the ATM Software, and may be amended only in writing signed by both parties.



## COMPLIANCE / EMISSION STATEMENTS

### DISCLAIMER

The manufacturer of the Automated Teller Machine (ATM) product(s) described herein makes no representations or warranties, either expressed or implied, by or with respect to anything in this manual, and shall not be liable for any implied warranties of fitness for a particular purpose or for any indirect, special, or consequential damages. Information in this document is subject to change without notice and does not represent a commitment on the part of the manufacturer.



#### **\*\* CAUTION \*\***

**Changes or modifications not expressly approved by Triton Systems could void the regulatory compliance approval and the warranty. Use of this product in a manner other than those described in this manual may result in personal injury!**

### EMISSIONS (EMI)

#### (US Requirements)

This device complies with Part 15 of the FCC rules. Operation is subject to the following two (2) conditions:

- 1) This device may not cause harmful interference.
- 2) This device must accept any interference received, including interference that may cause undesired operation.

#### NOTE:

This equipment has been tested and found to comply with the limits for a Class A digital device pursuant to Part 15 of FCC rules. These limits are designed to provide reasonable protection against harmful interference when the equipment is operated in a commercial environment. This equipment generates, uses, and can radiate radio frequency energy and, if not installed and used in accordance with the instruction manual, may cause harmful interference to radio communications. Operation of this equipment in a residential area is likely to cause harmful interference in which case the user will be required to correct the interference at his own expense. Changes or modifications to this unit not expressly approved by the party responsible for compliance could void the user's authority to operate the equipment.

#### CANADIAN REQUIREMENTS

This digital apparatus does not exceed the Class A limits for radio noise emissions from digital apparatus set in the Radio Interference Regulations of the Canadian Department of Communications. This Class A digital apparatus complies with Canadian ICES-003.

Le present appareil numerique n'emet pas de bruits radioelectriques dépassant les limites applicables aux appareils numeriques de la Class A prescrites dans le Reglement sur le brouillage radioelectrique edicte par le ministere des Communications du Canada. Cet appareil numerique de la classe A est conforme a la norme NMB-003 Canada.

#### UK / AUSTRALIA / SOUTH AFRICA REQUIREMENTS

##### Warning:

This is a Class A product. In a domestic environment, this product may cause radio interference in which case the user may be required to take adequate measures.

**APPENDIX B**  
**WARRANTY STATEMENT**

## APPENDIX B - WARRANTY STATEMENT

---

### WARRANTY STATEMENT

Manufacturer warrants that the Products delivered to Distributor will perform in accordance with the Manufacturer's published specifications, and as outlined in the Manufacturer's booklet entitled "Thirteen Months Parts Only Limited Warranty" for thirteen months from date of shipment in Long Beach, MS. Distributor acknowledges that it has received a copy of such booklet, that it has read its entirety and that it understands and agrees with its contents.

Manufacturer's warranty shall not apply to any damage resulting from abuse, negligence, accident, or to any loss or damage to the products while in transit.

Written notice and explanation of circumstances surrounding any claims that the goods have proved defective in material or workmanship shall be given promptly from the distributor to the manufacturer. No claim may be made, or action brought, by or through a distributor after the expiration of 14 months following any alleged breach of warranty.

**DISTRIBUTOR'S SOLE AND EXCLUSIVE REMEDY IN THE EVENT OF DEFECT IS EXPRESSLY LIMITED TO THE REPLACEMENT OR CORRECTION OF SUCH DEFECTIVE PARTS BY MANUFACTURER AT ITS ELECTION AND SOLE EXPENSE, EXCEPT THERE SHALL BE NO OBLIGATION TO REPLACE OR REPAIR ITEMS WHICH, BY THEIR NATURE, ARE EXPENDABLE.** If Manufacturer is unable to replace or repair the defective parts, Manufacturer shall refund to Distributor that portion of the purchase price allocable pays to such goods.

No representation or other affirmation of fact not set forth herein, including but not limited to statements regarding capacity, suitability for use, or performance of the goods, shall be or be deemed to be a warranty or representation by Manufacturer for any purpose, nor give rise to any liability or obligation of Manufacturer whatever.

**EXCEPT AS SPECIFICALLY PROVIDED IN THIS DOCUMENT, THERE ARE NO OTHER WARRANTIES EXPRESSED OR IMPLIED INCLUDING, BUT NOT LIMITED TO, ANY IMPLIED WARRANTIES OR MERCHANTABILITY OR FITNESS FOR A PARTICULAR PURCHASE.**

### LIMITATION OF LIABILITY

**IN NO EVENT SHALL MANUFACTURER BE LIABLE FOR LOSS OF PROFITS OR INCIDENTAL, INDIRECT, SPECIAL, CONSEQUENTIAL OR OTHER SIMILAR DAMAGES ARISING OUT OF ANY BREACH OF THIS CONTRACT OR OBLIGATIONS UNDER THIS CONTRACT.**

### DEFENSE OF INFRINGEMENT CLAIMS

If notified promptly in writing of any action (and all prior claims relating to such action) brought against the Distributor based on a claim that Distributor's use of the goods infringes a patent or other intellectual property right, and if given access by Distributor to any information distributor has regarding such alleged infringement, Manufacturer agrees to defend Distributor in such action at its expense and will pay any costs or damages finally awarded against Distributor in any such action, provided the Manufacturer shall have had sole control of the defense of any such action and all negotiations for its settlement or compromise.

## APPENDIX B - WARRANTY STATEMENT

---

In the event that a final injunction shall be obtained against the Distributor's use of the goods or any of their parts by reason of infringement of a patent or other intellectual property right or if in Manufacturer's opinion the goods are likely to become the subject of a claim of infringement of a patent or other intellectual property right, Manufacturer will, at its option and at its expense, either procure for the Distributor the right to continue using the goods, replace or modify the same so they become non-infringing or grant the Distributor a credit for such goods as depreciated and accept their return. The depreciation shall be an equal amount per year over the lifetime of the goods as established by Manufacturer.

Manufacturer shall not have any liability to the Distributor under any provision of this clause if any infringement, or claim thereof, is based upon: (i) the use of the goods in combination with other goods or devices which are not made by Manufacturer; (ii) the use of the goods in practicing any process; (iii) the furnishing to the Distributor of any information, date, service, or applications assistance; or (iv) the use of the goods with modifications made by the Distributor. The Distributor shall hold Manufacturer harmless against any expense, judgment or loss for infringement of any patent or other intellectual property right which results from Manufacturer's compliance with the Distributor's designs, specifications or instructions. No costs or expenses shall be incurred for the account of Manufacturer without the written consent of Manufacturer. **THE FOREGOING STATES THE ENTIRE LIABILITY OF MANUFACTURER WITH RESPECT TO INFRINGEMENT OF PATENTS OR OTHER INTELLECTUAL PROPERTY RIGHT BY THE GOODS OR ANY PART THEREOF, OR BY THEIR OPERATION.**

### INTERPRETATION AND OTHER PAROLE EVIDENCE

This writing is intended by the parties as final expression of their agreement and is intended also as a complete and exclusive statement of the terms of their agreement. No course of prior dealing between the parties and no usage of the trade shall be relevant to supplement or explain any term used in these terms and conditions. Acceptance or acquiescence in a course of performance rendered under these terms and conditions shall not be relevant to determine the meaning of these terms and conditions even though the accepting or acquiescing party has knowledge of the performance and opportunity for objection. Whenever a term defined by the Uniform Commercial Code, as adopted in Mississippi, is used in these terms and conditions, the definition contained in the code is to control.

### MODIFICATIONS

These terms and conditions can be modified or rescinded only by writing signed by both the parties or their duly authorized agents.

### WAIVER INEFFECTIVE

No claim or right arising out of or relating to a breach of these terms and conditions can be discharged in whole or in part by a waiver or renunciation of the claim or right unless the waiver or renunciation is supported by consideration and is in writing signed by the aggrieved party. Waiver by either Manufacturer or Distributor of a breach by the other of any provision of these terms and conditions shall not be deemed a waiver of future compliance therewith, and such provisions shall remain in full force and effect.

## APPENDIX B - WARRANTY STATEMENT

---

### STATUTE OF LIMITATIONS

Any action by the Distributor or Manufacturer for breach of these terms and conditions must be commenced within one (1) year after the cause of action has accrued.

### APPLICABLE LAW

These terms and conditions shall be governed by and construed in accordance with the provisions of the Uniform Commercial Code as adopted by the State of Mississippi.

### BANKRUPTCY

In the event of any proceedings, voluntary or involuntary, in bankruptcy or insolvency by or against Distributor, or in the event of the appointment, with or without the Distributor's consent, of an assignee for the benefit of creditors or of a receiver or of a liquidator, then Manufacturer shall be entitled to cancel any unfilled part of these terms and conditions without any liability whatsoever.

### PARTS ONLY LIMITED MANUFACTURER'S WARRANTY

Triton Systems of Delaware, Inc. warrants the components of each FT7000 ATM, excluding software and related documentation, against any defect in materials and/or workmanship for a period of 13 months from the shipping date. If a component fails due to defects in materials and/or workmanship within the warranty period, Triton will furnish a new or refurbished component, at its discretion. Triton shall not be responsible for labor or other costs associated with installing the components and the failed component shall be returned to Triton at the purchaser's expense. Triton shall not be responsible for misuse or abuse of a unit and any attempts to remove or deface the serial number or date code on a unit or any component thereof, or any attempt to repair a unit or to repair or replace any component by anyone other than a service technician authorized by Triton shall void this warranty.

#### **Limited Warranty covers normal use. Triton does not warrant or cover damage:**

- occurring during shipment of the equipment or components from or to Triton's facilities;
- caused by accident, impact with other objects, dropping, falls, spilled liquids, or immersion in liquids;
- caused by a disaster such as fire, flood, wind, earthquake, lightning, or other acts of God;
- caused by failure to provide a suitable installation environment for the equipment, including but not limited to, faulty wiring in the building in which the equipment is installed, installation in a facility with uncontrolled environmental conditions, failure to provide a dedicated electrical circuit on which the equipment operates, and/or lack of proper earth grounding for the equipment;
- caused by the use of the equipment for purposes other than those for which it was designed;
- resulting from improper maintenance;
- caused by any other abuse, misuse, mishandling, or misapplication.

Under no circumstances shall Triton or its suppliers be liable for any special, incidental, or consequential damages based upon breach of warranty, breach of contract, negligence, strict liability, or any other legal theory. Such damages include, but are not limited to, loss of profits, loss of revenue, loss of data, loss of use of the equipment or any associated equipment, cost of capital, cost of substitute or replacement equipment, facilities or services, downtime, purchaser's time, the claims of third parties, including customers, and injury to property.

## APPENDIX B - WARRANTY STATEMENT

---

### DISCLAIMER OF WARRANTIES

The warranty stated above is the only warranty applicable to this product. All other warranties, expressed or implied (including all implied warranties of merchantability or fitness for a particular purpose or quality of service), are hereby disclaimed. No oral or written information, or advice given by Triton, its agents or employees shall create a warranty or in any way increase the scope of this warranty.

### SHIPPING DAMAGE

All equipment is shipped Free On Board (FOB), Triton's facilities. The organization or individual who has purchased the equipment assumes responsibility for the equipment once it leaves Triton's facilities.

Should your equipment be damaged in the process of shipment or delivery to your place of destination, we recommend the following course of action:

- If possible, call the shipping company before the driver leaves your delivery site. Make note of the damage on the "receipt of delivery" paperwork. If this is not possible, call them as soon as possible to report the damage.
- Take photographs of the damaged packaging prior to opening the boxes. If this is not possible, make note of key points, such as whether the equipment is on a pallet, if the banding is intact, how the boxes are damaged, etc. Keep all of the packaging for inspection by the shipping company.
- If you unpack the equipment, take photographs of the damaged equipment. If this is not possible, make note of the damages.
- You must file a claim with the shipper for shipping damages immediately after reporting the damages.

Should you specify the carrier, we recommend that you explore with this chosen carrier the policies and procedures regarding shipping damage claims prior to selecting them as your preferred carrier.

If the equipment receives structural damage and is in an un-installable condition, Triton will work with you to arrange for a replacement unit to be shipped as soon as possible. The purchaser will be billed for the replacement unit. Triton's repair technicians will repair the damaged unit after it is returned to our facilities. We will credit the purchaser's account for the full purchase price of the damaged unit, minus the cost of returning the unit to "like new" condition. Under no circumstances does Triton authorize anyone to complete structural damage repairs in the field. Therefore, we will not ship primary structural parts, such as a cabinet head or main cabinet body for repair in the field.

## APPENDIX B - WARRANTY STATEMENT

---

### AUTHORIZED INSTALLATION AND SERVICE PROVIDERS

Triton utilizes several nationwide and regional authorized third party maintenance providers. Triton recommends all ATMs be installed and serviced by service technicians certified by Triton. This includes authorized third party service technicians and technicians who have been factory trained by Triton to service ATM equipment. Installation or repairs attempted by unauthorized service technicians may void the warranty or warranty claims denied on the product.

Please contact Triton's Technical Services department at (800) 259-6672 for a list of our third party service providers and/or to obtain information on the requirements and procedures for becoming a certified Triton service technician.

### TRITON'S TECHNICAL SERVICES DEPARTMENT

The primary purpose of the Technical Services department is to provide assistance to customers in the operation, trouble shooting, and repair of equipment manufactured by Triton. A toll-free phone number (1-800-259-6672) is provided for convenience. The Technical Services department operates to serve our customers. The staff is trained to follow our policies and procedures to ensure fair and uniform treatment of all our customers.

### AUTOMATED VOICE MAIL SYSTEM

Our goal is to have a 'live' person answer 100% of all incoming calls (during regular support hours). On occasion, however, call loads may exceed the capacity of the staff. When this occurs, an automated voice mail system will answer the call, indicate to the caller that all Technical Support specialists are busy assisting others, and ask the caller to leave detailed information about the nature of the call.

Should it become necessary to leave a voice mail message, the caller should state:

- their name,
- the organization for which they work,
- the **serial number** of the equipment they are calling about,
- detailed description of the problem that they are experiencing, and
- phone number where they can be reached, including area code.

As Technical Support specialists become available, they check for voice mail messages and return calls in the order in which they were received. By providing the information requested in the voice mail, the technician can be prepared when your call is returned. Triton asks you to be patient if you must leave voice mail and assures you that your call is important to us and that we will respond promptly.

## APPENDIX B - WARRANTY STATEMENT

---

### CALLS FOR SERVICE OR REPAIR

Calls for service or repair will be accepted from authorized service technicians only. End users must contact either the sales organization that placed the equipment or an authorized third party service organization to obtain service. The sections that follow describe the policies and procedures that relate to the repair and replacement of malfunctioning equipment.

### QUESTIONS ON OPERATION OF EQUIPMENT

Technical support is available to owners of Triton equipment and to qualified service personnel. When calling for help with the configuration or operation of a Triton product, the caller must provide either positive identification as a service technician or the serial number of a Triton terminal. Technical support is provided during normal business hours for the life of the product.

When calling for help with an operational problem, please have available information pertaining to the nature of the trouble. This includes the type of equipment, examples of what is or is not happening, and the name of the processor that supports your terminal.

All questions pertaining to the settlement of accounts, transaction inquiries, and fund status must be directed to the processor. Triton does not have access to the information needed to answer questions relating to specific transactions.

### CONTACT INFORMATION

Triton Systems of Delaware, Inc.  
522 East Railroad Street  
Long Beach, MS 39560

#### SERVICE:

1 (800) 259-6672 (Technical Support)  
1 (228) 575-3229 Fax (Technical Support)  
1 (228) 868-0859 Fax (Parts)



**APPENDIX C**  
**ELECTRONIC LOCK AND BATTERY**



### Entering the Combination

The electronic lock combination(s) consists of six digits. Upon arrival, the combination(s) of the lock should already be set at **1-2-3-4-5-6**. After installation of the unit has been completed, perform the following steps:

1. Enter the preset combination and check for proper operation. After each key-press, the lock will beep. After the final digit has been entered, the lock will beep twice and the open period will begin.
2. Within **four (4)** seconds, turn the keypad clockwise to the open position.
3. After the lock is opened, the door may be opened.

**Invalid Code Entry** - Lock will beep three (3) times.

### Changing the Combination

#### \* Important \*

Always perform this operation with the door open.

If your unit is programmed for Dual Code (see **Programmable Features**), each code must be changed independently. Follow these instructions for each code change.

To change the combination of the lock, simply follow these directions.

1. Enter **six (6) zeros**.
2. Enter the **current** combination (initially set at **1-2-3-4-5-6**).
3. Enter the **new** six (6) digit combination **twice**.
  - If a mistake is made, wait thirty (30) seconds and repeat the first 3 steps.
4. Test lock combination several times before closing the door. The combination is now changed.

**Valid Code Entry** - Double signal after valid six (6) digit code is entered.

**Invalid Code Entry** - Triple signal and old code is still valid.

## Lockout Feature

The lock includes a **WRONG TRY PENALTY** lockout feature that prevents entry from unauthorized personnel. This feature performs as follows:

- Entry of four (4) consecutive invalid combinations starts a 5-minute delay period.
  - LED flashes RED at ten (10) second intervals.
- At the end of the delay period, two (2) more consecutive invalid combinations will restart an additional 5-minute delay. **Entry will not respond to a single keystroke during delay period.**

## Programmable Features

The locks are initially set with the standard features (a single 6-digit code). Based on your requirements, additional features may be added in the lock, **BUT THEY MUST BE PRE-PROGRAMMED by Triton** prior to shipment of the unit. The programmable features are listed below.

**Manager** (Factory set to 1-2-3-4-5-6):

Add/remove second user

Enable/disable second user

**Dual Code:**

Two (2) combinations required to open.

**Silent Signal Alarm (Optional alarm box required):**

Duress signal if last number of code(s) is entered using one (1) number higher or one (1) number lower. Time Delay:

Delay period 1-99 minutes.

Open period 1-19 minutes

**Time Delay Override:**

Ability to add second combination to override delay period

**Disable Lock (Optional alarm box required):**

Input signal disables opening of lock by valid code

If your lock(s) have some of these features programmed in the lock, the following describe the operations of each:

**Add User**

(If Manager, Time Delay Override, Remote Override, or Dual Combination feature programmed)

**- Always perform this operation with the door(s) open!**

1. Enter Manager Code and HOLD DOWN LAST DIGIT OF CODE until the lock signals with two (2) sets of double beeps.
2. PRESS 1. Lock signals twice. Lock will only signal twice if the User code is not already in use. It will beep once if a User is already installed and three (3) times if the function has not been programmed in the lock.
3. Enter User code twice. The lock signals twice after each valid entry.
4. If a mistake is made, wait thirty (30) seconds and repeat steps 1 through 3.

**Valid Code Entry** - Double signal after valid six (6) digit code is entered.

**Invalid Code Entry** - Triple signal and old code is still valid.

**Disable User**

(Manager feature only)

**- Always perform this operation with the door(s) open!**

1. Enter Manager Code and HOLD DOWN LAST DIGIT OF CODE until the lock signals with two (2) sets of double beeps.
2. PRESS 2. Lock signals once. User is now temporarily disabled.
3. If a mistake is made, wait thirty (30) seconds and repeat steps 1 and 2.

### **Reinstate User**

(Manager feature only)

**- Always perform this operation with the door(s) open!**

1. Enter Manager Code and HOLD DOWN LAST DIGIT OF CODE until the lock signals with two (2) sets of double beeps.
2. PRESS 1. Lock signals once. User is now reinstated.
3. If a mistake is made, wait thirty (30) seconds and repeat steps 1 and 2.

### **Remove User**

(Manager feature only)

**- Always perform this operation with the door(s) open!**

1. Enter Manager Code and HOLD DOWN LAST DIGIT OF CODE until the lock signals with two (2) sets of double beeps.
2. PRESS 3. Lock signals once. User is now permanently removed.
3. If a mistake is made, wait thirty (30) seconds and repeat steps 1 and 2.

### **Dual Code Operation**

(if feature is programmed)

**- Always perform this operation with the door(s) open!**

1. Must add second user to open lock (See **ADD USER**).
  - Second user **CAN NOT** be Disabled or Removed.
2. After first code is entered, second code must be entered within ten (10) seconds.
3. If Time Delay f - Always perform this operation with the door(s) open!
  - Both codes required to open lock in Open period.

### Silent Signal Alarm

(if feature is programmed AND optional Alarm Box is connected to an alarm system)

**- Always perform this operation with the door(s) open!**

1. Enter last digit of code one (1) number higher or one (1) number lower.  
Example: Code: 1-2-3-4-5-6  
Duress: 1-2-3-4-5-5 or 1-2-3-4-5-7
2. The lock will open without any indication that the duress signal has been sent.

### Time Delay

(if feature is programmed)

**- Always perform this operation with the door(s) open!**

1. Enter valid code.
  - Delay period starts (1-99 minutes pre-programmed).
  - LED flashes RED at one (1) second intervals.
    - If valid code entered during delay, Delay period restarts.
    - If invalid code(s) entered during delay, Delay period aborts.
2. At end of delay period, Open period starts (1-19 minutes pre-programmed).
  - LED flashes RED at 1/2 second intervals.
  - Lock beeps at ten (10) second intervals
3. During Open period, enter valid code(s).
  - If invalid code entered during open, Open period continues.
  - If four (4) consecutive invalid codes entered, **WRONG TRY PENALTY** starts.

**Time Delay Override**  
(if feature is programmed)

**- Always perform this operation with the door(s) open!**

1. Must add second code (See ADD USER).
  - Second user CAN NOT be Disabled or Removed.
2. Entry of Over ride code during Delay period will open lock.

**Battery Low Warning**

Repeated beeping during an opening indicates that the battery is low and needs to be replaced. Recommend replacement of battery at least once annually. The battery box is located on the inside of the door.

**Note:** If the lock will not operate (i.e. repeated beeping or no beeping) while the door is closed and locked, the battery must be energized from the two external terminals on the front of the push-button panel.

To energize the lock, connect a 9-volt alkaline battery on the external terminal points. Maintain contact, enter a valid combination, and turn the dial clockwise to open the lock.

**Note: You must maintain battery contact at all times throughout this procedure.**

---

## Changing the Battery

1. Open the ATM vault door(s). Remove the battery box cover by pulling the front portion away from the vault door.
2. The connector is easily removed by unsnapping it from the two (2) terminal on the top of the battery.
3. Remove the old battery. Install/connect a new 9-volt alkaline battery.
4. Push the battery and the leads completely up into the battery compartment.
5. Reinstall the cover and test the unit several times before closing the vault door.

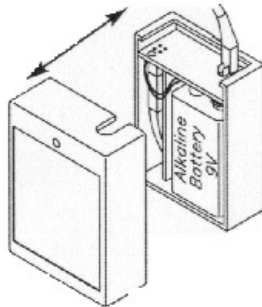



# APPENDIX D

## MECHANICAL LOCKS

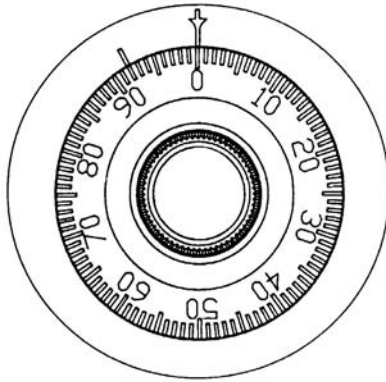

## Entering the Combination

There are two marks on the dial ring (Refer to Figure 1). The index at the top is used for opening the lock, The index 30 degrees to the left is used only when changing the combination.

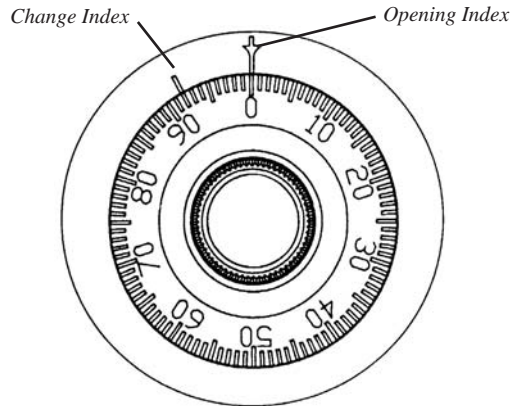

Figure 1. The changing and opening indices on the dial ring of the mechanical combination lock dial.

The dial should always be turned slowly and evenly. A revolution is counted each time the selected number is aligned with the opening index. **DO NOT TURN THE DIAL BACK TO COMPENSATE FOR OVER DIALING A NUMBER.** If, when dialing the combination, any number is turned beyond the index, the entire sequence must be repeated. Locks are shipped on a single number **factory setting of '50'**. To unlock, turn the dial to the left (counterclockwise) **FOUR** turns stopping on '50'. Then, turn the dial to the right until the bolt is retracted. The Mas Hamilton lock is the only mechanical lock shipped with a factory combination of **"50-25-50"**.

### UNLOCKING A 3-NUMBER COMBINATIONS

(EXAMPLE, "25-10-25")

1. Turn the dial to the **LEFT**, stopping when '25' is aligned with the opening index, the **FOURTH** time.
2. Turn the dial to the **RIGHT**, stopping when '10' is aligned with the opening index, the **THIRD** time.
3. Turn the dial to the **LEFT**, stopping when '25' is aligned with the opening index, the **SECOND** time.
4. Turn the dial slowly to the **RIGHT** until the bolt retracts.

**LOCKING THE LOCK**

Turn the dial to the **LEFT** at least four full revolutions.

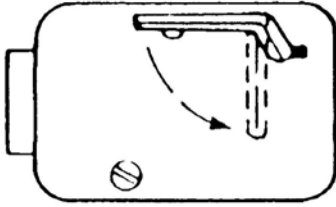

Figure 2. Turn the change key one-quarter turn counterclockwise to allow a new combination to be entered.

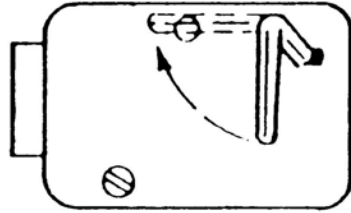

Figure 3. After entering the last number of the combination, turn the change key one-quarter turn clockwise and remove the key.

**CHANGING THE COMBINATION**

Select three new numbers. **DO NOT** use any number between 1 and 20 for the last number.

For maximum security, do not use numbers that end in 0 or 5, and do not use numbers in sequence: e.g., '27-48-86' is not as good as '27-86-48". Perform the following steps:

1. Dial the existing combination on the opening index (see steps 1-2-3 previously, or the directions for opening when on the factory setting). Open door of container.
2. Refer to Figure 1. Dial the existing combination again, using the changing index.
3. With the last number set at the changing index, hold the dial securely and insert the change key in the keyhole in the back of the lock. Make sure the wing is entirely inside the lock and comes to a positive stop (see Figure 2) before turning the key.
4. Turn key one-quarter turn to the **LEFT** (see Figure 2). With the change key in this position, set the new combination as follows:
  - a. Turn the dial to the **LEFT**, stopping when the first number of the new combination aligns with the changing index the **FOURTH** time.
  - b. Turn the dial to the **RIGHT**, stopping when the second number is aligned with the changing index, the **THIRD** time.
  - c. Turn the dial to the **LEFT**, stopping when the third number is aligned with the changing index, the **SECOND** time. Holding the dial in this position, turn the change key back to the **RIGHT** and remove it (See Figure 3). The new combination you have chosen is now set in the lock.

**TEST THE NEW COMBINATION BEFORE CLOSING THE DOOR**

**SUPPLEMENT A**  
**T5 AND T7 PCI-EPP**  
**BATTERY REPLACEMENT PROCEDURES**

## T5 PCI-EPP BATTERY REPLACEMENT

### **\*\* CAUTION \*\***

**You must not remove battery from EPP without FIRST connecting a new battery! This EPP will be permanently damaged if unpowered and battery is removed before connecting a new battery!**



**Battery Case**

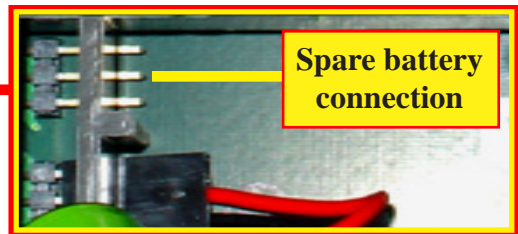
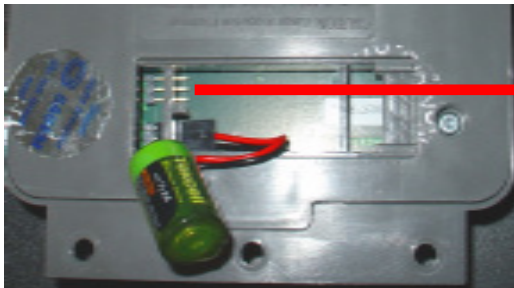

**Spare battery connection**

**EXISTING BATTERY - DO NOT REMOVE BEFORE CONNECTING A SPARE BATTERY FIRST!**

The spare battery for the T5 PCI-EPP may be purchased from Triton Systems:  
**P/N 01300-00025 (T5 PCI-EPP Lithium Backup Battery)**

## T7 PCI-EPP BATTERY REPLACEMENT

### **\* IMPORTANT\***

You may remove the battery without risk of damage to the EPP. You have approximately 2-5 minutes to replace with a spare battery before losing the data stored (keys, passwords) in the keypad.

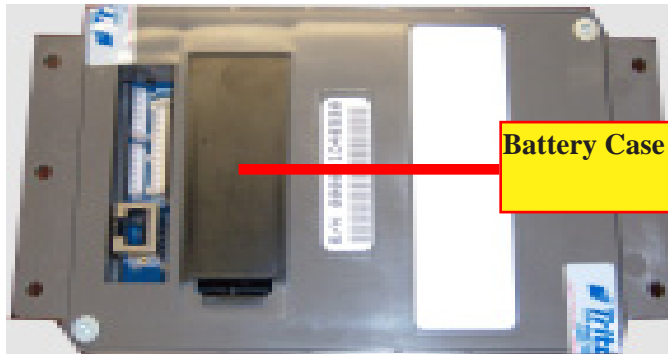

The spare battery for the T7 PCI-EPP may be purchased from Triton Systems:  
**P/N 01300-00023 (T7 PCI-EPP Lithium Battery)**



T5 PCI-EPP

## SUPPLEMENT B

# KEY MANAGEMENT PROCEDURES

T7 PCI-EPP



## PCI-EPP (T5) / KEY MANAGEMENT PROCEDURES

### DIFFERENCES WITH THE T5 PCI-EPP KEYPAD

1

**YOU MUST NOT REMOVE BATTERY FROM EPP WITHOUT FIRST CONNECTING A NEW BATTERY! THIS T5 EPP WILL BE PERMANENTLY DAMAGED IF UNPOWERED AND BATTERY IS REMOVED BEFORE CONNECTING A NEW BATTERY!**

2

- **USER PASSWORDS MUST BE AT LEAST 8 CHARACTERS, RATHER THAN 6.**
- **EPP WILL PROMPT WITH ERROR IF FEWER CHARACTERS ENTERED AND THEN TAKE YOU BACK TO PASSWORD ENTRY AT POINT YOU LEFT OFF.**
- **THERE IS NO WAY TO CLEAR THE PASSWORD. HIT <CANCEL> AND START OVER.**

3

- **NO <CLEAR> OR <BACKSPACE> ON KEY ENTRY.**
- **IF ERROR IS MADE IN KEY ENTRY, HIT <CANCEL> AND START KEY ENTRY OVER FROM BEGINNING OF FIRST KEY HALF.**

4

- **YOU MAY ONLY ENTER IN NEW KEYS - NO CHANGE KEY FUNCTIONALITY.**

5

- **YOU HAVE 10 MINUTES TO ENTER IN BOTH USER PASSWORDS BEFORE TIMEOUT.**
  - **IF TIMEOUT OCCURS, YOU MUST START KEY ENTRY OVER FROM SCRATCH.**
  - ***THIS WILL AFFECT STAGING OF UNITS!***
  - **CANNOT ENTER ONE KEY HALF AT WAREHOUSE AND OTHER HALF IN FIELD.**

6

- **PASSWORD ENTRY – CLEAR WILL TAKE YOU BACK TO KEY MANAGEMENT PAGE.**
  - **RE-ENTER PASSWORD.**



# SUPPLEMENT B - KEY MANAGEMENT PROCEDURES

## KEY MANAGEMENT PROCEDURES (w/T5 PCI-EPP INSTALLED)

- ① ENTER MANAGEMENT FUNCTIONS > MAIN MENU > KEY MANAGEMENT.

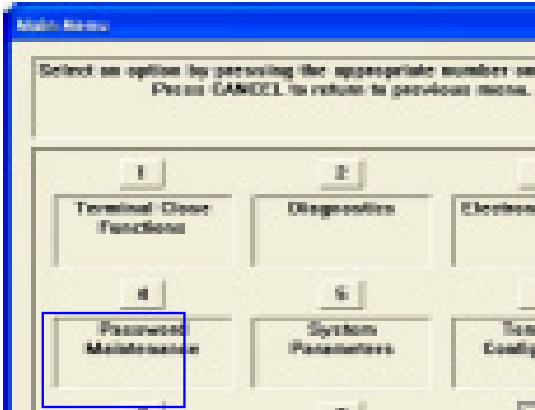

- ② THE "SET PASSWORD INITIALIZATION" PROMPT APPEARS. PRESS <ENTER>.

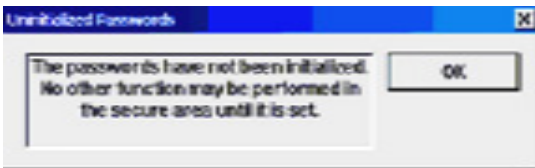

- ③ SELECT "SET PASSWORD" OPTION.

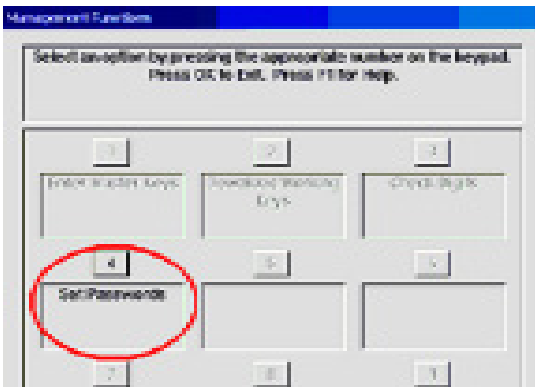

- ④ *NOTE: PREVIOUSLY, USERS HAD TO ENTER THE INITIAL PASSWORD OF SIX (6) "ZEROS" BEFORE BEING ALLOWED TO SET THE PASSWORDS. THIS IS NO LONGER REQUIRED (FOR T5 PCI-EPP ONLY).*

- SELECT "SET USER 1 PASSWORD" OPTION. ENTER NEW PASSWORD FOR USER 1. PASSWORDS CAN BE ANYWHERE FROM '8' TO '16' DECIMAL DIGITS. PRESS <ENTER>.
- YOU WILL BE PROMPTED AGAIN TO CONFIRM THE NEW PASSWORD. RE-ENTER NEW PASSWORD. PRESS <ENTER>. AFTER THE PASSWORD IS INITIALIZED, THE "SET USER 1 PASSWORD" OPTION CHANGES TO "CHANGE USER 1 PASSWORD".

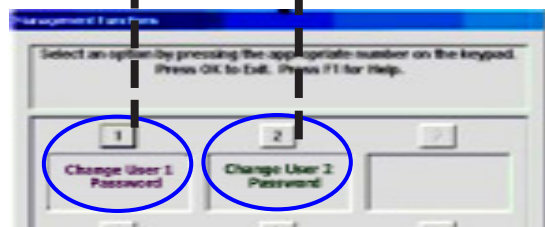
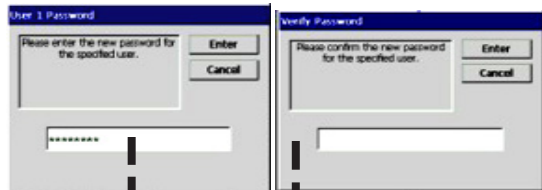

- NEXT, SELECT "SET USER 2 PASSWORD" OPTION. FOLLOW THE SAME PROCEDURE FOR ENTERING A NEW PASSWORD FOR USER 2.

WHEN COMPLETED, THE "SET USER 2 PASSWORD" OPTION WILL CHANGE TO "CHANGE USER 2 PASSWORD".

AFTER COMPLETION, HIT <CANCEL> TO ENTER MASTER KEYS SCREEN (STEP 5).

⑤ SELECT “ENTER MASTER KEYS” OPTION.

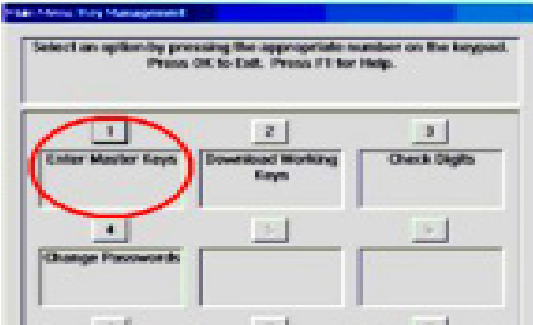

**IMPORTANT: THE REST OF THE PROCEDURES MUST BE COMPLETED WITHIN A 10 MINUTE PERIOD. IF THE PROCESS TAKES LONGER THAN THAT, THE KEY PARTS WILL NOT BE ABLE TO BE COMBINED!**

⑥ ENTER USER 1 PASSWORD. PRESS <ENTER>. ENTER USER 2 PASSWORD. PRESS <ENTER>.

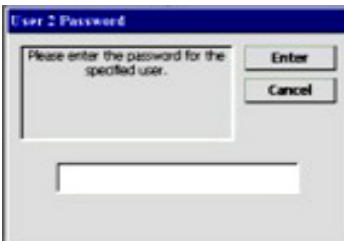

⑦ SELECT “ENTER PIN MASTER KEY” OPTION.

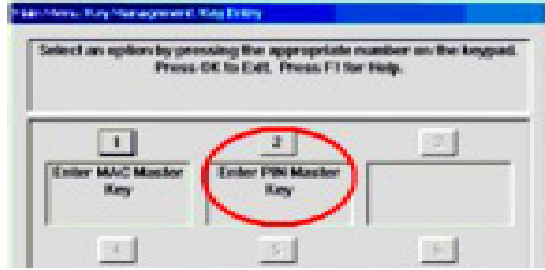

⑧ USER 1 ENTERS THE FIRST KEY PART (32 CHARACTERS). REFERENCE THE KEY LAYOUT DISPLAY BELOW. THE MAIN KEYPAD WILL MIRROR THE NUMBER/ALPHANUMERIC KEYS.

AFTER ENTERING THE KEYS, PRESS THE <ENTER> OPTION ON THE RIGHT-SIDE FUNCTION KEY <F7>.

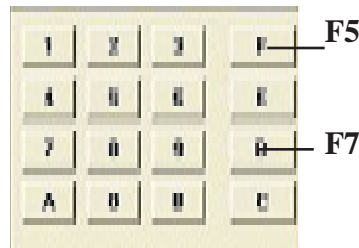

## SUPPLEMENT B - KEY MANAGEMENT PROCEDURES

- ⑨ THE “CHECK DIGITS” PROMPT APPEARS.  
PRESS <ENTER>.

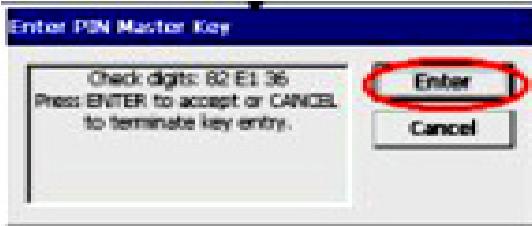

A PROMPT APPEARS TO ENTER THE SECOND KEY PART. PRESS <ENTER>.



- ⑩ USER 2 ENTERS THE SECOND KEY PART (32 CHARACTERS). REFER TO STEP 8 FOR ENTERING KEYS.

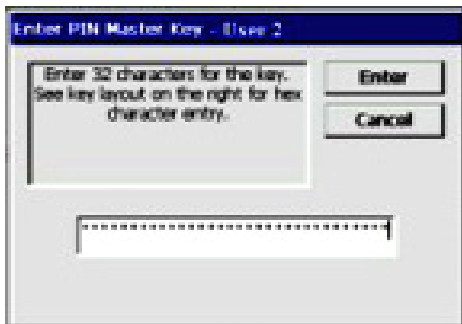

- ⑪ THE “CHECK DIGITS” PROMPT APPEARS.



YOU WILL BE PROMPTED THAT THE KEY WAS SUCCESSFULLY CHANGED.



REPEAT SEQUENCE FOR ENTERING MAC MASTER KEY, IF REQUIRED.

**KEY MANAGEMENT PROCEDURES (w/T7 PCI-EPP INSTALLED)**

① ENTER MANAGEMENT FUNCTIONS > MAIN MENU > KEY MANAGEMENT.

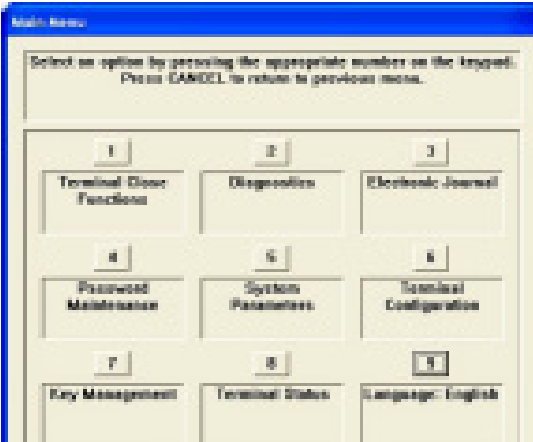

② THE “SET PASSWORD INITIALIZATION” PROMPT APPEARS. PRESS <ENTER>.

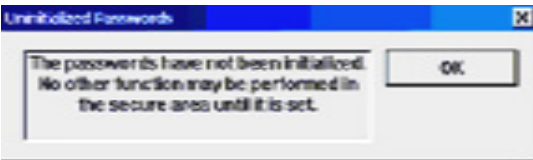

③ SELECT “SET PASSWORD” OPTION.

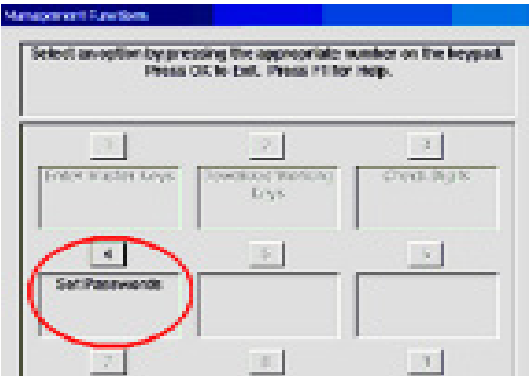

④ THE T7 USER PASSWORDS ARE INITIALLY SET TO SIX (6) “ZEROS (SIMILAR TO VEPP) BEFORE BEING ALLOWED TO SET THE PASSWORDS.

> SELECT “SET USER 1 PASSWORD” OPTION. ENTER NEW PASSWORD FOR USER 1. PASSWORDS CAN BE ANYWHERE FROM ‘6’ TO ‘14’ DECIMAL DIGITS. PRESS <ENTER>.

> YOU WILL BE PROMPTED AGAIN TO CONFIRM THE NEW PASSWORD. RE-ENTER NEW PASSWORD. PRESS <ENTER>.

AFTER THE PASSWORD IS INITIALIZED, THE “SET USER 1 PASSWORD” OPTION CHANGES TO “CHANGE USER 1 PASSWORD”.

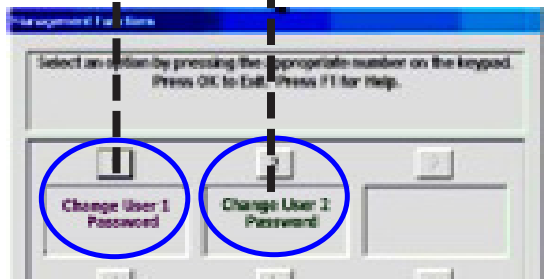
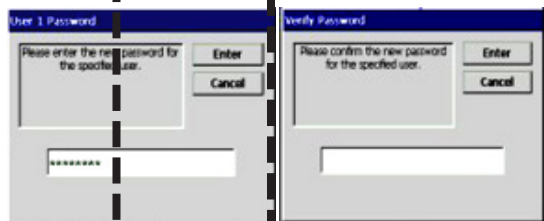
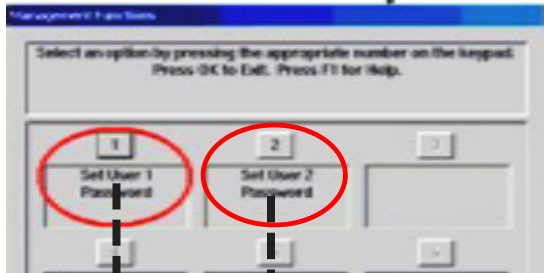

## SUPPLEMENT B - KEY MANAGEMENT PROCEDURES

➤ NEXT, SELECT “SET USER 2 PASSWORD” OPTION. FOLLOW THE SAME PROCEDURE FOR ENTERING A NEW PASSWORD FOR USER 2.

WHEN COMPLETED, THE “SET USER 2 PASSWORD” OPTION WILL CHANGE TO “CHANGE USER 2 PASSWORD”.

AFTER COMPLETION, HIT <CANCEL> TO ENTER MASTER KEYS SCREEN (STEP 5).

⑤ SELECT “ENTER MASTER KEYS” OPTION.

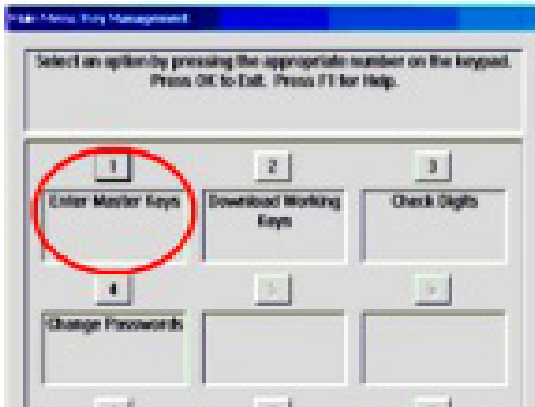

⑥ ENTER USER 1 PASSWORD. PRESS <ENTER>.

ENTER USER 2 PASSWORD. PRESS <ENTER>.

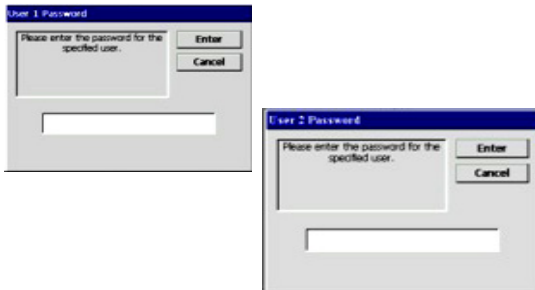

⑦ SELECT “ENTER PIN MASTER KEY” OPTION.

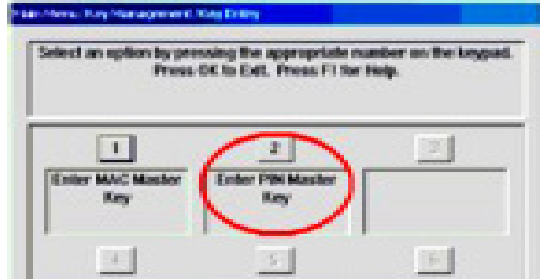

⑧ USE THE <ARROW> KEY TO TOGGLE BETWEEN “NEW KEY” OR “ADD PART” (TO AN EXISTING KEY).

PRESS <ENTER> FOR THE APPLICABLE ENTRY.

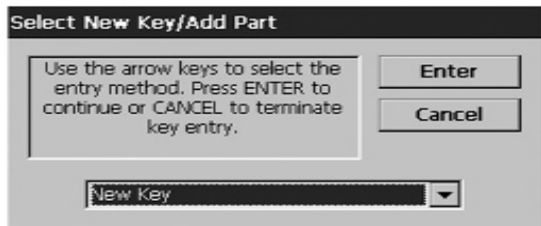

⑨ USER 1 ENTERS THE FIRST KEY PART (32 CHARACTERS). REFERENCE THE KEY LAYOUT DISPLAY BELOW. THE MAIN KEYPAD WILL MIRROR THE NUMBER/ALPHANUMERIC KEYS.

AFTER ENTERING THE KEYS, PRESS THE <ENTER> OPTION ON THE RIGHT-SIDE FUNCTION KEY <F7>.

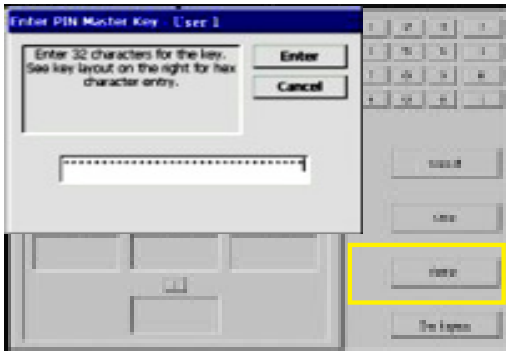

⑩ THE “CHECK DIGITS” PROMPT AP-  
PEARS. PRESS <ENTER>.

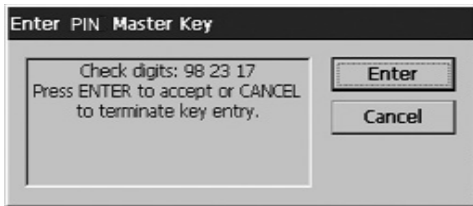

A PROMPT APPEARS TO ENTER THE SECOND  
KEY PART. PRESS <ENTER>.



⑪ USER 2 ENTERS THE SECOND KEY  
PART (32 CHARACTERS). REFER TO STEP 9  
FOR ENTERING KEYS.

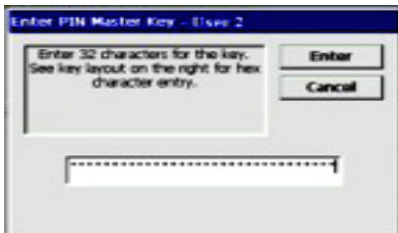

⑫ THE “CHECK DIGITS” PROMPT AP-  
PEARS.

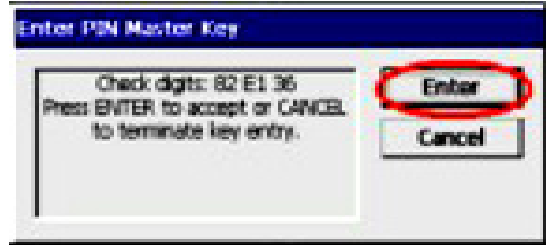

YOU WILL BE PROMPTED THAT THE  
KEY WAS SUCCESSFULLY CHANGED.

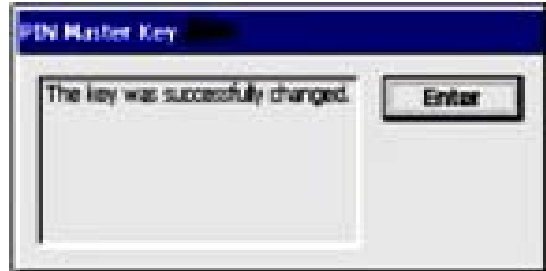

REPEAT SEQUENCE FOR ENTERING MAC  
MASTER KEY , IF REQUIRED.